

Uni-I/O™ is a family of Input/Output modules that are compatible with the UniStream™ control platform.

This guide provides basic installation information for the UIA-0402N module. Technical specifications may be downloaded from the Unitronics website.

The UniStream™ platform comprises CPU controllers, HMI panels, and local I/O modules that snap together to form an all-in-one Programmable Logic Controller (PLC).

Install Uni-I/O™ modules:

- Onto the back of any UniStream™ HMI Panel comprising a CPU-for-Panel.
- Onto a DIN-rail, using a Local Expansion Kit.

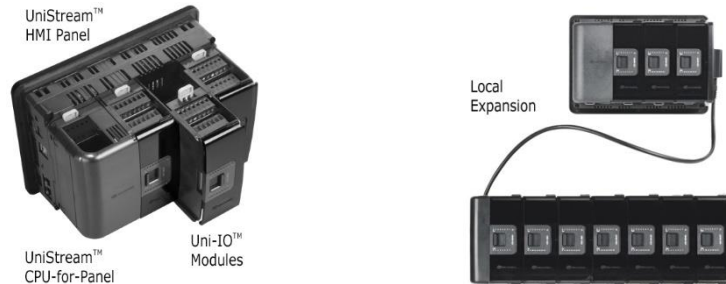

The maximum number of Uni-I/O™ modules that can be connected to a single CPU controller is limited. For details, please refer to the specification sheets of the UniStream™ CPU or any of the relevant Local Expansion Kits.

Before You Begin

Before installing the device, the installer must:

- Read and understand this document.
- Verify the Kit Contents.



Installation option requirements

If you are installing a Uni-I/O™ module onto:

- A UniStream™ HMI Panel; the Panel must comprise a CPU-for-Panel, installed according to the CPU-for-Panel installation guide.
- A DIN-rail; you must use a Local Expansion Kit, available by separate order, to integrate the Uni-I/O™ modules on the DIN-rail into a UniStream™ control system.

Alert Symbols and General Restrictions

When any of the following symbols appear, read the associated information carefully.

Symbol	Meaning	Description
	Danger	The identified danger causes physical and property damage.
	Warning	The identified danger could cause physical and property damage.
Caution	Caution	Use caution.

- All examples and diagrams are intended to aid understanding, and do not guarantee operation. Unitronics accepts no responsibility for actual use of this product based on these examples.
- Please dispose of this product according to local and national standards and regulations.
- This product should be installed only by qualified personnel.

-  Failure to comply with appropriate safety guidelines can cause severe injury or property damage.
- Do not attempt to use this device with parameters that exceed permissible levels.
- Do not connect/disconnect the device when power is on.

Environmental Considerations

- ⚠️ ▪ Ventilation: 10mm (0.4") of space is required between the device top/bottom edges and the enclosure's walls.
- Do not install in areas with: excessive or conductive dust, corrosive or flammable gas, moisture or rain, excessive heat, regular impact shocks or excessive vibration, in accordance with the standards and limitations given in the product's technical specification sheet.
- Do not place in water or let water leak onto the unit.
- Do not allow debris to fall inside the unit during installation.
- Install at maximum distance from high-voltage cables and power equipment.

Kit Contents

- 1 UIA-0402N module
- 4 I/O terminal blocks (2 black and 2 gray)

UIA-0402N Diagram

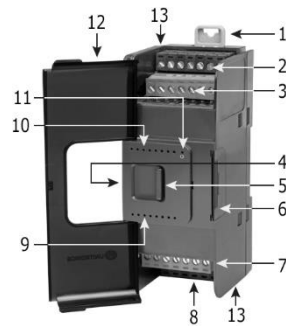

1	DIN-rail clips	Provide physical support for CPU and modules. There are two clips: one at the top (shown), one at the bottom (not shown).
2	Inputs 0-1	Input connection points
3	Inputs 2-3	
4	I/O Bus - Left	Left-side Connector
5	Bus Connector Lock	Slide the Bus Connector Lock to the left, to electrically connect the Uni-I/O™ module to the CPU or adjacent module.
6	I/O Bus - Right	Right-Side Connector, shipped covered. Leave covered when not in use.
	Bus Connector Cover	
7	Output 1	Output connection points
8	Output 0	

9	Output LEDs	Red LEDs
10	Input LEDs	Red LEDs
11	Status LED	Tricolor LED, Green/Red/Orange

NOTE ▪ Refer to the module's specification sheet for LED indications.

12	Module door	Shipped covered with protective tape to prevent the door from being scratched. Remove tape during installation.
13	Screw holes	Enable panel-mounting; hole diameter: 4mm (0.15").

About the I/O Bus Connectors

The I/O Bus connectors provide the physical and electrical connection points between modules. The connector is shipped covered by a protective cover, protecting the connector from debris, damage, and ESD.

The I/O Bus - Left (#4 in diagram) can be connected to either a CPU-for-Panel, a Uni-COM™ module, to another Uni-I/O™ module or to the End Unit of a Local Expansion Kit.

The I/O Bus - Right (#6 in diagram) can be connected to another I/O module, or to the Base Unit of the Local Expansion Kit.

Caution ▪ If the I/O module is located last in the configuration, and nothing is to be connected to it, do not remove its Bus Connector Cover.

Installation

- ⚠ ▪ Turn off system power before connecting or disconnecting any modules or devices.
- Use proper precautions to prevent Electro-Static Discharge (ESD).

Installing a Uni-I/O™ Module onto a UniStream™ HMI Panel

NOTE The DIN-rail type structure on the back of the panel provides the physical support for the Uni-I/O™ module.

1. Check the unit to which you will connect the Uni-I/O™ module to verify that its Bus Connector is not covered.
If the Uni-I/O™ module is to be the last one in the configuration, do not remove the cover of its I/O Bus Connector - Right.

2. Open the door of the Uni-I/O™ module and hold it as shown in the accompanying figure.

3. Use the upper and lower guide-tunnels (tongue & groove) to slide the Uni-I/O™ module into place.

4. Verify that the DIN-rail clips located at the top and bottom of the Uni-I/O™ module have snapped onto the DIN-rail.

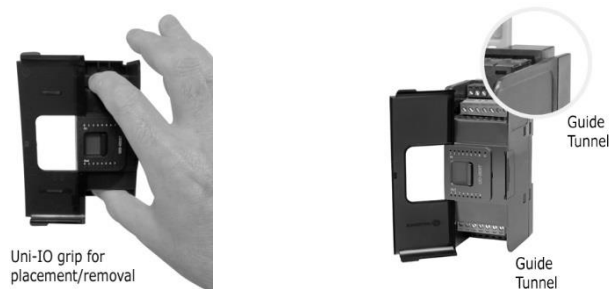

5. Slide the Bus Connector Lock all the way to the left as shown in the accompanying figure.
6. If there is already a module located to its right, complete the connection by sliding the Bus Connector lock of the adjacent unit to the left.
7. If the module is the last in the configuration, leave the I/O bus connector covered.

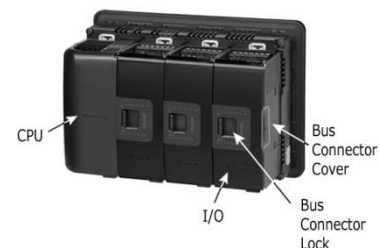

Removing a Module

1. Turn off the system power.
2. Disconnect the I/O terminals (#2,3,7,8 in the diagram).
3. Disconnect the Uni-I/O™ module from the adjacent units: slide its Bus Connector Lock to the right. If there is a unit located on its right, slide the lock of this module to the right as well.
4. On the Uni-I/O™ module, pull the top DIN-rail clip up and the bottom clip down.
5. Open the door of the Uni-I/O™ and hold it with two fingers as shown in the figure on page 3; then pull it carefully from its place.

Installing Uni-I/O™ modules onto a DIN-rail

To mount modules onto a DIN-rail, follow steps 1-7 in Installing a Uni-I/O™ Module onto a UniStream™ HMI Panel on page 3.

In order to connect the modules to a UniStream™ controller, you must use a Local Expansion Kit.

These kits are available with and without power supplies, and with cables of varying lengths. For complete information, please refer to the installation guide of the relevant Local Expansion Kit.

Numbering Modules

You can number modules for reference purposes. A set of 20 stickers is provided with every CPU-for-Panel; use these stickers to number the modules.



- The set contains numbered and blank stickers as shown in the figure to the left.
- Place them on the modules as shown in the figure to the right.



UL Compliance

The following section is relevant to Unitronics' products that are listed with the UL.

The following models: UIA-0006, UID-0808R, UID-W1616R,UIS-WCB1 are UL listed for Hazardous Locations.

The following models: UIA-0006, UIA-0402N,UIA-0402NL,UIA-0800N,UID-0016R,UID-0016RL, UID-0016T, UID-0808R, UID-0808RL, UID-0808T, UID-0808THS, UID-0808THSL, UID-0808TL, UID-1600, UID-1600L, UID-W1616R, UID-W1616T, UIS-04PTKN, UIS-04PTN, UIS-08TC, UIS-WCB1, UIS-WCB2 are UL listed for Ordinary Location.

UL Ratings, Programmable Controllers for Use in Hazardous Locations,

Class I, Division 2, Groups A, B, C and D

These Release Notes relate to all Unitronics products that bear the UL symbols used to mark products that have been approved for use in hazardous locations, Class I, Division 2, Groups A, B, C and D.

Caution ▪ This equipment is suitable for use in Class I, Division 2, Groups A, B, C and D, or Non-hazardous locations only.

- ⚡ ▪ Input and output wiring must be in accordance with Class I, Division 2 wiring methods and in accordance with the authority having jurisdiction.
 - ⚠ ▪ WARNING—Explosion Hazard—substitution of components may impair suitability for Class I, Division 2.
 - WARNING – EXPLOSION HAZARD – Do not connect or disconnect equipment unless power has been switched off or the area is known to be non-hazardous.
 - WARNING – Exposure to some chemicals may degrade the sealing properties of material used in Relays.
 - This equipment must be installed using wiring methods as required for Class I, Division 2 as per the NEC and/or CEC.
-

Certification UL des automates programmables, pour une utilisation en environnement à risques,

Class I, Division 2, Groups A, B, C et D.

Cette note fait référence à tous les produits Unitronics portant le symbole UL - produits qui ont été certifiés pour une utilisation dans des endroits dangereux, Classe I, Division 2, Groupes A, B, C et D.

Attention ▪ Cet équipement est adapté pour une utilisation en Classe I, Division 2, Groupes A, B, C et D, ou dans Non-dangereux endroits seulement.

- ⚡ ▪ Le câblage des entrées/sorties doit être en accord avec les méthodes de câblage selon la Classe I, Division 2 et en accord avec l'autorité compétente.
 - ⚠ ▪ AVERTISSEMENT: Risque d'Explosion – Le remplacement de certains composants rend caduque la certification du produit selon la Classe I, Division 2.
 - AVERTISSEMENT - DANGER D'EXPLOSION - Ne connecter pas ou ne débranche pas l'équipement sans avoir préalablement coupé l'alimentation électrique ou la zone est reconnue pour être non dangereuse.
 - AVERTISSEMENT - L'exposition à certains produits chimiques peut dégrader les propriétés des matériaux utilisés pour l'étanchéité dans les relais.
 - Cet équipement doit être installé utilisant des méthodes de câblage suivant la norme Class I, Division 2 NEC et /ou CEC.
-

Wiring

- ⚠ This equipment is designed to operate only at SELV/PELV/Class 2/Limited Power environments.
- All power supplies in the system must include double insulation. Power supply outputs must be rated as SELV/PELV/Class 2/Limited Power.
- Do not connect either the 'Neutral' or 'Line' signal of the 110/220VAC to device's 0V point.
- Do not touch live wires.

- ⚠ All wiring activities should be performed while power is OFF.
- Use over-current protection, such as a fuse or circuit breaker, to avoid excessive currents into the UIA-0402N supply port.
- Unused points should not be connected (unless otherwise specified). Ignoring this directive may damage the device.
- Double-check all wiring before turning on the power supply.

- Caution
- To avoid damaging the wire, use a maximum torque of 0.5 N·m (5 kgf·cm).
 - Do not use tin, solder, or any substance on stripped wire that might cause the wire strand to break.
 - Install at maximum distance from high-voltage cables and power equipment.

Wiring Procedure

Use crimp terminals for wiring; use 26-12 AWG wire (0.13 mm² –3.31 mm²).

1. Strip the wire to a length of 7±0.5mm (0.250–0.300 inches).
2. Unscrew the terminal to its widest position before inserting a wire.
3. Insert the wire completely into the terminal to ensure a proper connection.
4. Tighten enough to keep the wire from pulling free.

UIA-0402N Connection Points

All wiring diagrams and instructions in this document refer to the UIA-0402N connection points.

These points are arranged in four groups of 7 points as shown in the figure to the right.

Two top groups

Input connection points

Two bottom groups

Outputs and power supply connection points

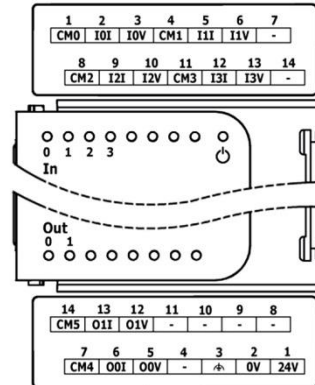

Wiring Guidelines

In order to ensure that the device will operate properly and to avoid electromagnetic interference:

- Use a metal cabinet. Make sure the cabinet and its doors are properly earthed.
 - Use wires that are properly sized for the load.
- Use shielded twisted pair cables for wiring Analog I/O signals; do not use the cable shield as a signal common (CM) / return path.
 - Route each I/O signal with its own dedicated common wire. Connect common wires at their respective common (CM) points at the I/O module.
- Individually connect each 0V point and each common (CM) point in the system to the power supply 0V terminal, unless otherwise specified.
 - Individually connect each functional ground point (⚡) to the earth of the system (preferably to the metal cabinet chassis).

Use the shortest and thickest wires possible: less than 1m (3.3') in length, minimum thickness 14 AWG (2 mm²).

- Connect the power supply 0V to the earth of the system.
- Earthing the cables' shield:
 - Connect the cable shield to the earth of the system - preferably to the metal cabinet chassis. Note that the shield must be connected only at one end of the cable; typically, earthing the shield at the UIA-0402N end performs better.
 - Keep shield connections as short as possible.
 - Ensure shield continuity when extending shielded cables.

NOTE For detailed information, refer to the document System Wiring Guidelines, located in the Technical Library in the Unitronics' website.

Wiring the Power Supply

This module requires an external 24VDC power supply.

- ⚠ ▪ The 0V of the UIA-0402N must be connected to the HMI Panel's 0V. Ignoring this directive may damage the device.
- In the event of voltage fluctuations or non-conformity to voltage power supply specifications, connect the device to a regulated power supply.

Connect the 24V and 0V terminals as shown in the accompanying figure.

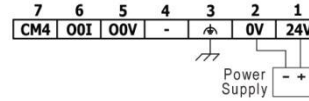

Wiring the Analog Inputs

- No** ▪ The inputs are not isolated.
- TE** ▪ Each input offers two modes: voltage or current. You can set each input independently. The mode is determined both by wiring and by the hardware configuration within the software application.
- Voltage and current modes use distinct points. Connect only the point associated with the selected mode; leave the other point unconnected
- Each input has its own common point (CM0 for I0, etc.).

Voltage

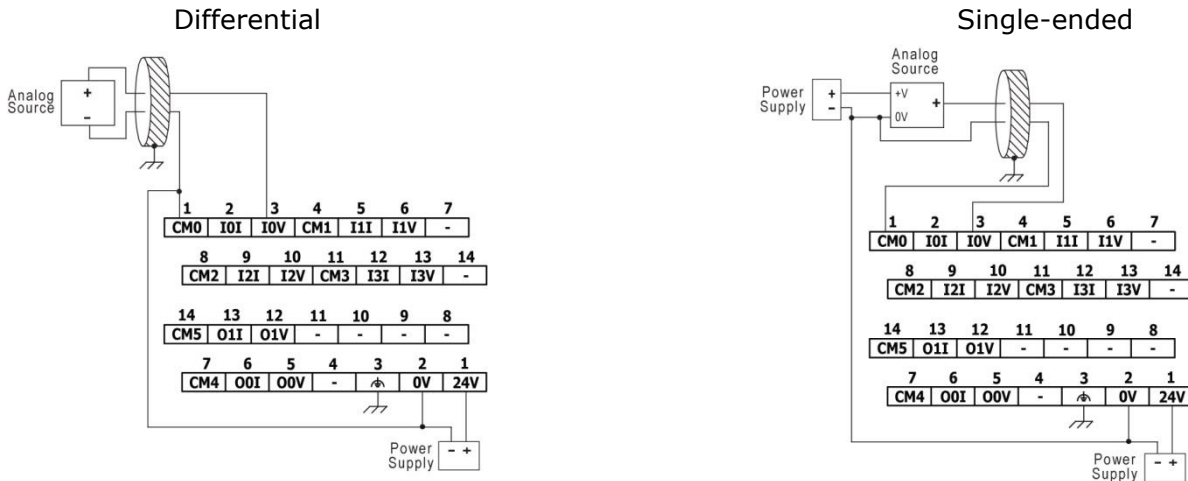

Current

2-wire

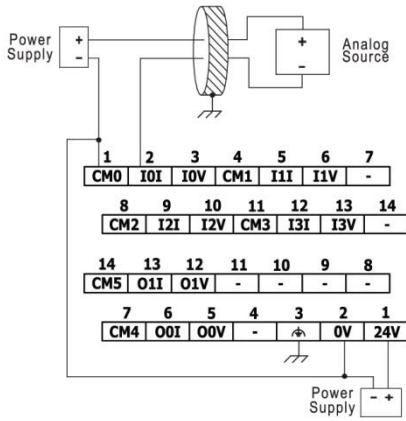

3-wire

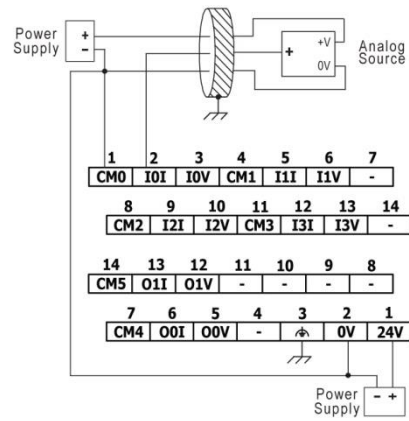

4-wire

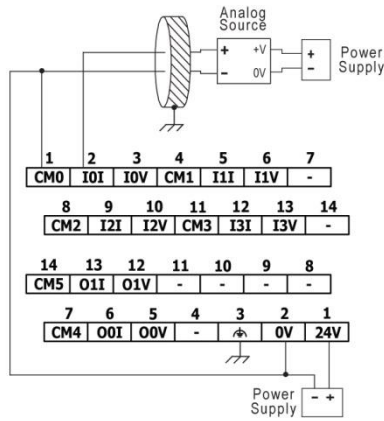

Wiring the Analog Outputs

- NOTE**
- The outputs are not isolated.
 - Each output offers two modes: voltage or current. You can set each output independently. The mode is determined both by wiring and by the hardware configuration within the software application.
 - Voltage and current modes use distinct points. Connect only the point associated with the selected mode; leave the other point unconnected.
 - Each output has its own common point (CM4 for O0, CM5 for O1). Connect each analog output using its corresponding CM point.
 - Do not connect CM4 or CM5 to the system 0V.



- Do not use points CM4 or CM5 for any purpose other than connecting the analog output load. Using them for any other purpose may damage the module.

Voltage

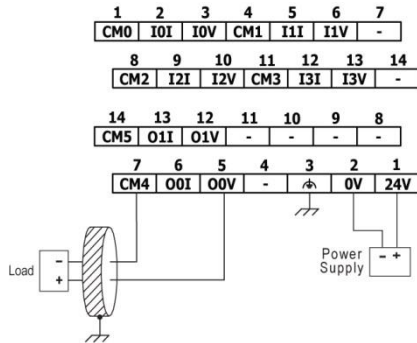

Current

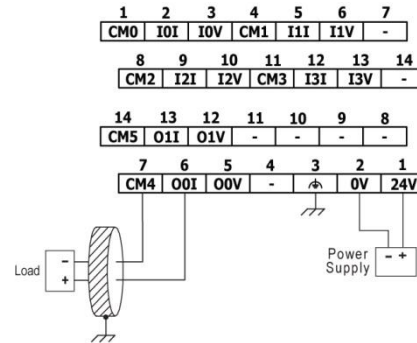

Technical Specifications

This guide provides specifications for Unitronics' Uni-I/O™ module UIA-0402N. This module comprises:

- 4 analog inputs, 13 bit
- 2 analog outputs, 13/14 bit

Uni-I/O modules are compatible with UniStream™ family of Programmable Logic Controllers. They may be either snapped onto the back of a UniStream™ HMI Panel next to a CPU-for-Panel to create an all-in-one HMI + PLC controller, or installed on a standard DIN Rail using a Local Expansion Adapter.

Installation Guides are available in the Unitronics Technical Library at www.unitronics.com

Analog Inputs					
Number of inputs	4				
Input range ^{(1) (2)}	Input Type	Nominal Values	Over-range Values	Overflow Values	
	0 ÷ 10VDC	$0 \leq V_{in} \leq 10VDC$	$10 < V_{in} \leq 10.15VDC$	$V_{in} > 10.15VDC$	
	0 ÷ 20mA	$0 \leq I_{in} \leq 20mA$	$20 < I_{in} \leq 20.3mA$	$I_{in} > 20.3mA$	
Absolute maximum rating	±30V (Voltage), ±30mA (Current)				
Isolation	None				
Conversion method	Successive approximation				
Resolution	13 bits				
Accuracy (25°C / -20°C to 55°C)	±0.3% / ±0.5% of full scale (Voltage) ±0.3% / ±0.4% of full scale (Current)				
Input impedance	552kΩ (Voltage), 118Ω (Current)				
Noise rejection	10Hz, 50Hz, 60Hz, 400Hz				
Step response ⁽³⁾ (0 to 100% of final value)	Smoothing	Noise Rejection Frequency			
		400Hz	60Hz	50Hz	10Hz
	None	2.7ms	16.86ms	20.2ms	100.2ms
	Weak	10.2ms	66.86ms	80.2ms	400.2ms
	Medium	20.2ms	133.53ms	160.2ms	800.2ms
	Strong	40.2ms	266.86ms	320.2ms	1600.2ms
Update time ⁽³⁾	Noise Rejection Frequency			Update Time	
	400Hz			1.25ms	
	60Hz			8.33ms	
	50Hz			10ms	
	10Hz			50ms	
Operational signal range (signal + common mode)	Voltage mode – IxV: -1V ÷ 12.5V ; CMx: -1V ÷ 2.5V Current mode – IxI: -1V ÷ 2.8V ; CMx: -1V ÷ 0.4V (x=0,1,2 or 3)				
Common mode rejection	30dB @ 10Hz, 50Hz, 60Hz or 400Hz noise rejection mode				

Normal mode rejection	60dB @ 10Hz, 50Hz or 60Hz noise rejection mode 45dB @ 400Hz noise rejection mode
Cable	Shielded twisted pair
Diagnostics ⁽⁴⁾	Analog input overflow

Analog Outputs				
Number of outputs	2			
Output range ⁽²⁾	Output Type	Nominal Values	Over-range Values	Overflow Values
	0 ÷ 10VDC	0 ≤ V _{out} ≤ 10VDC	10 < V _{out} ≤ 10.15VDC	V _{out} > 10.15VDC
	-10 ÷ 10VDC	-10 ≤ V _{out} ≤ 10VDC	-10.15 ≤ V _{out} < -10VDC 10 < V _{out} ≤ 10.15VDC	V _{out} < -10.15VDC V _{out} > 10.15VDC
	0 ÷ 20mA	0 ≤ I _{out} ≤ 20mA	20 ≤ I _{out} ≤ 20.3mA	I _{out} > 20.3mA
	4 ÷ 20mA	4 ≤ I _{out} ≤ 20mA	20 ≤ I _{out} ≤ 20.3mA	I _{out} > 20.3mA
Isolation	None			
Resolution	0 ÷ 10VDC – 14 bit -10 ÷ 10VDC – 13 bit + sign 0 ÷ 20mA – 13 bit 4 ÷ 20mA – 13 bit			
Accuracy (25°C / -20°C to 55°C)	±0.3% / ±0.5% of full scale (Voltage) ±0.5% / ±0.7% of full scale (Current)			
Load impedance	Voltage – 2kΩ minimum Current – 600Ω maximum			
Settling time (95% of new value)	0 ÷ 10VDC – 1.8ms (2kΩ resistive load), 3.7ms (2kΩ + 1uF load) -10 ÷ 10VDC – 3ms (2kΩ resistive load), 5.5ms (2kΩ + 1uF load) 0 ÷ 20mA and 4 ÷ 20mA – 1.7ms (600Ω load), 1.7ms (600Ω + 10mH load)			
Cable	Shielded twisted pair			
Diagnostics ⁽⁴⁾	Voltage – Short circuit Current – Open circuit			

Power Supply	
Nominal operating voltage	24VDC
Operating voltage	20.4 ÷ 28.8VDC
Maximum current consumption	150mA @ 24VDC
Diagnostics ⁽⁴⁾	Supply level: Normal / Low or missing.

IO/COM Bus	
Bus current consumption	120mA maximum

LED Indications			
Input LEDs	Red	On: Input value is in Overflow	
Output LEDs	Red	On: Short Circuit (when set to Voltage mode) Open Circuit (when set to Current mode)	
Status LED	A triple color LED. Indications are as follows:		
	Color	LED State	Status
	Green	On	Operating normally
		Slow blink	Boot
		Rapid blink	OS initialization
	Green/Red	Slow blink	Configuration mismatch
	Red	On	Supply voltage is low or missing
		Slow blink	No IO exchange
		Rapid blink	Communication error
	Orange	Rapid Blink	OS Upgrade
Slow Blink		Firmware Error, Contact Support	

Environmental	
Protection	IP20, NEMA1
Operating temperature	-20°C to 55°C (-4°F to 131°F)
Storage temperature	-30°C to 70°C (-22°F to 158°F)
Relative Humidity (RH)	5% to 95% (non-condensing)
Operating altitude	2,000 m (6,562 ft)
Shock	IEC 60068-2-27, 15G, 11ms duration
Vibration	IEC 60068-2-6, 5Hz to 8.4Hz, 3.5mm constant amplitude, 8.4Hz to 150Hz, 1G acceleration

Dimensions	
Weight	0.15 Kg (0.331 lb)
Size	Refer to the images below

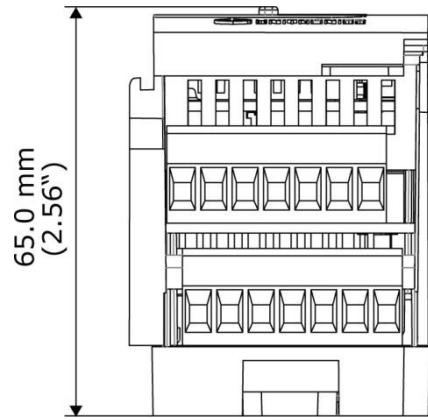

Top View

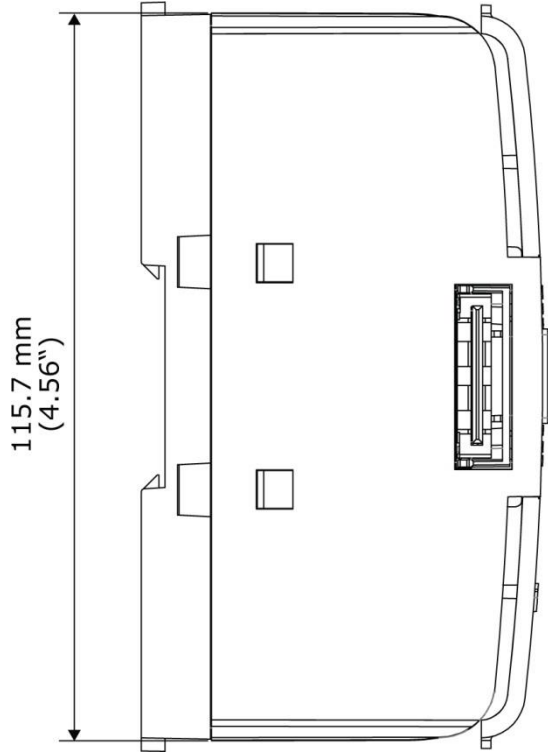

Side View

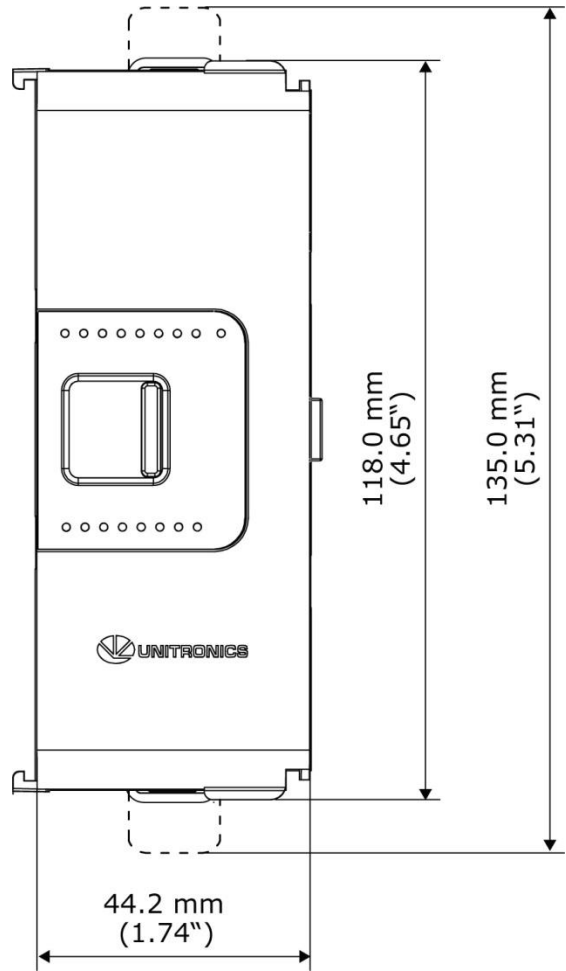

Front View

Notes:

1. The 4-20mA input option is implemented using 0-20mA input range.
2. The UIA-0402N measures values that are up to 1.5% higher than the nominal input range (i.e. Input Over-range). Similarly, it will be able to output values that are up to 1.5% higher than the nominal output range (Output Over-range).
Note that when the input overflow occurs, it is indicated in the corresponding system tag while the input value is registered as the maximum permissible value. For example, if the specified input range is 0–10V, the Over-range values can reach up to 10.15V, and any input voltage higher than that will still register as 10.15V while the Overflow system tag is turned on.
3. Step response and update time are independent of the number of channels that are used.
4. See LED Indications Table above for description of the relevant indications. Note that the diagnostics results are also indicated in the system tags and can be observed through the UniApps™ or the online state of the UniLogic™.

The information in this document reflects products at the date of printing. Unitronics reserves the right, subject to all applicable laws, at any time, at its sole discretion, and without notice, to discontinue or change the features, designs, materials and other specifications of its products, and to either permanently or temporarily withdraw any of the forgoing from the market.

All information in this document is provided "as is" without warranty of any kind, either expressed or implied, including but not limited to any implied warranties of merchantability, fitness for a particular purpose, or non-infringement. Unitronics assumes no responsibility for errors or omissions in the information presented in this document. In no event shall Unitronics be liable for any special, incidental, indirect or consequential damages of any kind, or any damages whatsoever arising out of or in connection with the use or performance of this information.

The tradenames, trademarks, logos and service marks presented in this document, including their design, are the property of Unitronics (1989) (R"G) Ltd. or other third parties and you are not permitted to use them without the prior written consent of Unitronics or such third party as may own them.

UG_UIA-0402N 06/24