



**EN** Operating instructions. . . . .pages 1 to 6  
Original

**Content**

**1 About this document**

1.1 Function . . . . . 1

1.2 Target group: authorised qualified personnel. . . . . 1

1.3 Explanation of the symbols used . . . . . 1

1.4 Appropriate use . . . . . 1

1.5 General safety instructions . . . . . 1

1.6 Warning about misuse . . . . . 2

1.7 Exclusion of liability . . . . . 2

**2 Product description**

2.1 Ordering code . . . . . 2

2.2 Special versions. . . . . 2

2.3 Purpose . . . . . 2

2.4 Technical data . . . . . 2

2.5 Safety classification . . . . . 3

**3 Mounting**

3.1 General mounting instructions . . . . . 3

3.2 Dimensions . . . . . 3

**4 Electrical connection**

4.1 General information for electrical connection. . . . . 3

**5 Operating principle and settings**

5.1 LED functions. . . . . 3

5.2 Description of the terminals . . . . . 3

5.3 Notes . . . . . 3

**6 Set-up and maintenance**

6.1 Functional testing. . . . . 4

6.2 Maintenance . . . . . 4

**7 Disassembly and disposal**

7.1 Disassembly. . . . . 4

7.2 Disposal . . . . . 4

**8 Appendix**

8.1 Wiring examples . . . . . 4

8.2 Start configuration . . . . . 4

8.3 Sensor configuration . . . . . 5

8.4 Actuator configuration . . . . . 5

**9 EU Declaration of conformity**

**1. About this document**

**1.1 Function**

This operating instructions manual provides all the information you need for the mounting, set-up and commissioning to ensure the safe operation and disassembly of the safety-monitoring module. The operating instructions must be available in a legible condition and a complete version in the vicinity of the device.

**1.2 Target group: authorised qualified personnel**

All operations described in this operating instructions manual must be carried out by trained specialist personnel, authorised by the plant operator only.

Please make sure that you have read and understood these operating instructions and that you know all applicable legislations regarding occupational safety and accident prevention prior to installation and putting the component into operation.

The machine builder must carefully select the harmonised standards to be complied with as well as other technical specifications for the selection, mounting and integration of the components.

**1.3 Explanation of the symbols used**



**Information, hint, note:**

This symbol is used for identifying useful additional information.



**Caution:** Failure to comply with this warning notice could lead to failures or malfunctions.

**Warning:** Failure to comply with this warning notice could lead to physical injury and/or damage to the machine.

**1.4 Appropriate use**

The products described in these operating instructions are developed to execute safety-related functions as part of an entire plant or machine. It is the responsibility of the manufacturer of a machine or plant to ensure the correct functionality of the entire machine or plant.

The safety-monitoring module must be exclusively used in accordance with the versions listed below or for the applications authorised by the manufacturer. Detailed information regarding the range of applications can be found in the chapter "Product description".



To avoid EMC disturbances, the physical ambient and operational conditions at the place where the product is installed, must meet the provisions laid down in the paragraph "Electromagnetic Compatibility (EMC)" of EN 60204-1.

**1.5 General safety instructions**

The user must observe the safety instructions in this operating instructions manual, the country specific installation standards as well as all prevailing safety regulations and accident prevention rules.



Further technical information can be found in the Schmersal catalogues or in the online catalogue on the Internet: [products.schmersal.com](http://products.schmersal.com).

The information contained in this operating instructions manual is provided without liability and is subject to technical modifications.

There are no residual risks, provided that the safety instructions as well as the instructions regarding mounting, commissioning, operation and maintenance are observed.

### 1.6 Warning about misuse



In case of inadequate or improper use or manipulations of the safety-monitoring module, personal hazards or damage to machinery or plant components cannot be excluded. The relevant requirements of the standards EN ISO 14119 and EN ISO 13850 must be observed.

### 1.7 Exclusion of liability

We shall accept no liability for damages and malfunctions resulting from defective mounting or failure to comply with this operating instructions manual. The manufacturer shall accept no liability for damages resulting from the use of unauthorised spare parts or accessories.

For safety reasons, invasive work on the device as well as arbitrary repairs, conversions and modifications to the device are strictly forbidden, the manufacturer shall accept no liability for damages resulting from such invasive work, arbitrary repairs, conversions and/or modifications to the device.

The safety-monitoring module must only be used when the enclosure is closed, i.e. with the front cover fitted.

## 2. Product description

### 2.1 Ordering code

This operating instructions manual applies to the following types:

#### SRB 201LC



Only if the action described in these operating instructions is carried out correctly will the safety function be safeguarded, including compliance with the Machinery Directive.

### 2.2 Special versions

For special versions, which are not listed in the order code below 2.1, these specifications apply accordingly, provided that they correspond to the standard version.

### 2.3 Purpose

The safety-monitoring modules for integration in safety circuits are designed for fitting in control cabinets. They are used for the safe evaluation of the signals of positive break position switches or safety sensors for safety functions on sliding, hinged and removable safety guards as well as emergency stop control devices and AOPD.

The safety function is defined as the opening of enabling circuits 13-14 and 23-24 when the inputs S11-S12 and/or S22-S23 are opened.

The safety-relevant current paths with the outputs contacts 13-14 and 23-24 meet the following requirements under observation of a PFH value assessment (also refer to chapter 2.5 "Safety classification"):

- Control category 4 - PL e to EN ISO 13849-1
- SIL 3 to IEC 61508
- SIL CL 3 to EN 62061

To determine the Performance Level (PL) to EN ISO 13849-1 of the entire safety function (e.g. sensor, logic, actuator), an assessment of all relevant components is required.



The entire concept of the control system, in which the safety component is integrated, must be validated to the relevant standards.

## 2.4 Technical data

### General data

Standards:	EN 60947-5-3, EN 50178, EN 60204-1, EN ISO 13849-1, IEC 61508
Climate resistance:	EN 60068-2-78
Mounting:	Snaps onto standard DIN rail to EN 60715
Terminal designations:	EN 60947-1
Material of the housings:	Plastic, glass-fibre reinforced thermoplastic, ventilated
Material of the contacts:	AgSnO, self-cleaning, positive drive
Weight:	160 g
Start conditions:	Automatic or start button
Feedback circuit (Y/N):	yes
Pull-in delay:	typ. 100 ms
Drop-out delay in case of emergency stop:	typ. 25 ms / max. 30 ms
Drop-out delay on "supply failure":	typ. 70 ms
Bridging in case of voltage drops:	typ. 60 ms

### Mechanical data

Connection type:	Screw connection
Cable section:	min. 0.25 mm <sup>2</sup> / max. 2.5 mm <sup>2</sup>
Connecting cable:	rigid or flexible
Tightening torque for the terminals:	0.6 Nm
With removable terminals (Y/N):	No
Mechanical life:	10 million operations
Electrical life:	Derating curve available on request
Resistance to shock:	30 g / 11 ms
Resistance to vibration in accordance with EN 60068-2-6:	10 ... 55 Hz, amplitude 0.35 mm

### Ambient conditions

Ambient temperature:	-25 °C ... +60 °C
Storage and transport temperature:	-40 °C ... +85 °C
Protection class:	Enclosure: IP40 Terminals: IP20 Clearance: IP54

### Insulation values to EN 60664-1

#### (Basic insulation between control circuit and output circuit):

Rated insulation voltage U <sub>i</sub> :	
- safety contact:	250 V
Rated impulse withstand voltage U <sub>imp</sub> :	
- safety contact 13-14, 23-24:	4 kV
Overvoltage category:	III
Degree of pollution:	2
EMC rating:	to EMC Directive
Altitude:	max. 2,000 m

### Electrical Data

Contact resistance in new state:	max. 100 mΩ
Power consumption:	max. 2.0 W / 5.2 VA
Rated operating voltage U <sub>e</sub> :	24 VDC -15% / +20%, residual ripple max. 10%, 24 VAC -15% / +10%
Frequency range:	50 / 60 Hz
Fuse rating for the operating voltage:	Internal electronic trip, tripping current > 500 mA, reset after approx. 1 sec.

### Monitored inputs

Short-circuit recognition (Y/N):	No
Wire breakage detection (Y/N):	Yes
Earth leakage detection (Y/N):	Yes
Number of NO contacts:	0
Number of NC contacts:	2
Cable lengths:	1- / 2-channel without cross-wire short detection: - 1,500 m = 1.5 mm <sup>2</sup> - 2,500 m = 2.5 mm <sup>2</sup>

Conduction resistance:	max. 40 Ω
------------------------	-----------

### Outputs

Number of safety contacts:	2
Number of auxiliary contacts:	0
Number of signalling outputs:	1
Switching capacity of the safety contacts 13-14, 23-24:	max. 250 V, 4 A ohmic (inductive in case of appropriate protective wiring); min. 5 V / 1 mA

Utilisation category to EN 60947-5-1:	AC-15: 230 V / 2 A DC-13: 24 V / 1 A
Fuse rating of the safety contacts:	external ( $I_k = 1000$ A) to EN 60947-5-1 Safety fuse 6 A quick blow, 4 A slow blow
Switching capacity signalling output Y1:	24 VDC / 100 mA
Fuse rating of the signalling output:	internal electronic trip, tripping current > 100 mA
Dimensions H x W x D:	100 mm x 22.5 mm x 121 mm

The data specified in this manual is applicable when the component is operated with rated operating voltage  $U_e \pm 0\%$ .

### 2.5 Safety classification

Standards:	EN ISO 13849-1, IEC 61508
PL:	up to e
Control category:	up to 4
DC:	99% (high)
CCF:	> 65 points
PFH value:	$\leq 2.00 \times 10^{-8}/h$
SIL:	suitable for SIL 3 applications
Mission time:	20 years

The PFH value of  $2.00 \times 10^{-8}/h$  applies to the combinations of contact load (current through enabling contacts) and number of switching cycles ( $n_{op/ly}$ ) mentioned in the table below. At 365 operating days per year and a 24-hours operation, this results in the below-mentioned switching cycle times ( $t_{cycle}$ ) for the relay contacts. Diverging applications upon request.

Contact load	$n_{op/ly}$	$t_{cycle}$
20 %	525,600	1.0 min
40 %	210,240	2.5 min
60 %	75,087	7.0 min
80 %	30,918	17.0 min
100 %	12,223	43.0 min

## 3. Mounting

### 3.1 General mounting instructions

Mounting: snaps onto standard DIN rails to EN 60715.

Snap the bottom of the enclosure slightly tilted forwards in the standard rail and push up until it latches in position.

### 3.2 Dimensions

All measurements in mm.

Device dimensions (H/W/D): 100 x 22.5 x 121 mm

## 4. Electrical connection

### 4.1 General information for electrical connection



The electrical connection may only be carried out by authorised personnel in a de-energised condition.



As far as the electrical safety is concerned, the protection against unintentional contact of the connected and therefore electrically interconnected apparatus and the insulation of the feed cables must be designed for the highest voltage, which can occur in the device.

Wiring examples: see appendix

## 5. Operating principle and settings

### 5.1 LED functions

- K1: Status channel 1
- K2: Status channel 2
- $U_i$ : Status internal operating voltage (LED is on, when the operating voltage on the terminals A1-A2 is ON and the fuse has not been triggered).

### 5.2 Description of the terminals

Voltages:	A1	+24 VDC / 24 VAC
	A2	0 VDC / 0 VAC
Inputs:	S11-S12	Input channel 1 (+)
	S11-S22	Input channel 2 (+)
Outputs:	13-14	1. safety enabling circuit
	23-24	2. safety enabling circuit
Start:	X1-X2	Feedback circuit and external reset
Signalling output:	Y1	K1 + K2 off, Y1 = high (+ 24 V)

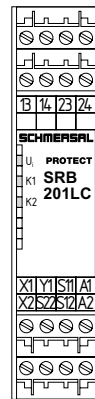

Fig. 1

### 5.3 Notes



Due to the operating principle of the electronic fuse, the customer must check that no hazard is caused by an unexpected restart in circuits without reset button (automatic reset).

### Signalling output Y1 (see Fig. 2)

The safety relays K1, K2 are signalled through signalling output Y1.



Signalling outputs must not be used in safety circuits.

K1	K2	Y1
On	On	low (0 V)
On	Off	low (0 V)
Off	On	low (0 V)
Off	Off	high (+ 24 V)

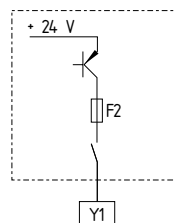

Fig. 2

6. Set-up and maintenance

6.1 Functional testing

The safety function of the safety-monitoring module must be tested. The following conditions must be previously checked and met:

1. Correct fixing
2. Check the integrity of the cable entry and connections
3. Check the safety-monitoring module's enclosure for damage
4. Check the electrical function of the connected sensor technology and their influence on the safety-monitoring module and the downstream actuators

6.2 Maintenance

A regular visual inspection and functional test, including the following steps, is recommended:

1. Check the correct fixing of the safety-monitoring module
2. Check the cable for damages
3. Check electrical function



If a manual functional check is necessary to detect a possible accumulation of faults, then this must take place during the intervals noted as follows:

- at least every month for PL e with category 3 or category 4 (according to EN ISO 13849-1) or SIL 3 with HFT (hardware fault tolerance) = 1 (according to EN 62061);
- at least every 12 months for PL d with category 3 (according to EN ISO 13849-1) or SIL 2 with HFT (hardware fault tolerance) = 1 (according to EN 62061).

Damaged or defective components must be replaced.

7. Disassembly and disposal

7.1 Disassembly

The safety-monitoring module must be disassembled in a de-energised condition only. Push up the bottom of the enclosure and hang out slightly tilted forwards.

7.2 Disposal

The safety-monitoring module must be disposed of in an appropriate manner in accordance with the national prescriptions and legislations.

8. Appendix

8.1 Wiring examples

Dual-channel control, shown for a guard door monitor with two position switches where one has a positive break contact; with external reset button <sup>®</sup> (Fig. 3)

- Relay outputs: Suitable for 2-channel control, for increase in capacity or number of contacts by means of contactors or relays with positive-guided contacts.
- The control system recognises wire-breakage and earth faults in the monitoring circuit.
- <sup>®</sup> = Feedback circuit

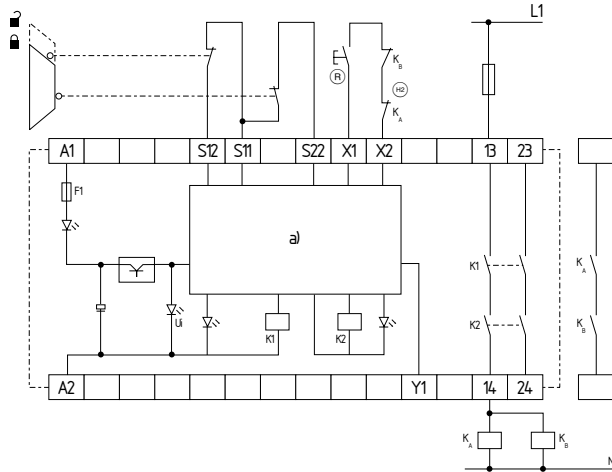

Fig. 3 a) Logic

8.2 Start configuration

External reset button (Fig. 4)

- The manual start or the activation of the module occurs when the button is pressed (not when it is released!).

Automatic start (see Fig. 5)

- The automatic start is programmed by connecting the feedback circuit to the terminals. If the feedback circuit is not required, establish a bridge.



Not admitted without additional measure due to the risk of gaining access by stepping behind!



Within the meaning of EN 60204-1 paragraph 9.2.3.4.2, the operating mode "automatic start" is only restrictedly admissible. In particular, any inadvertent restart of the machine must be prevented by other suitable measures.



Due to the operating principle of the electronic fuse, the customer must check that no hazard is caused by an unexpected restart in circuits without reset button (automatic reset).

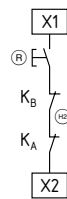

Fig. 4

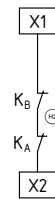

Fig. 5

8.3 Sensor configuration

**Single-channel emergency stop circuit with command devices to EN ISO 13850 and EN 60947-5-5 (Fig. 6)**

- Wire breakage and earth leakage in the control circuits are detected.
- Control category 1 – PL c to EN ISO 13849-1 possible, when tested to EN ISO 13849-1, paragraph 6.5.2.

**Dual-channel emergency stop circuit with command devices to EN ISO 13850 and EN 60947-5-5 (Fig. 7)**

- Wire breakage and earth leakage in the control circuits are detected.
- Cross-wire shorts between the control circuits are not detected.
- Control category 4 – PL e to EN ISO 13849-1 possible (with protective wiring)

**Single-channel guard door monitoring circuit with interlocking devices to EN ISO 14119 (Fig. 8)**

- At least one contact with positive break required.
- Wire breakage and earth leakage in the control circuits are detected.
- Control category 1 – PL c to EN ISO 13849-1 possible, when tested to EN ISO 13849-1, paragraph 6.5.2.

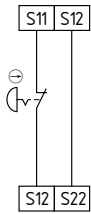

Fig. 6

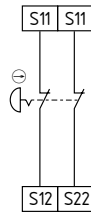

Fig. 7

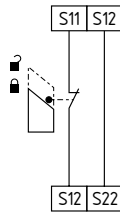

Fig. 8

**Dual-channel guard door monitoring circuit with interlocking device to EN ISO 14119 (Fig. 9)**

- With at least one positive-break position switch
- Wire breakage and earth leakage in the control circuits are detected.
- Cross-wire shorts between the control circuits are not detected.
- Control category 4 – PL e to EN ISO 13849-1 possible (with protective wiring)

**Dual-channel control of magnetic safety sensors to EN 60947-5-3 (see Fig. 10)**

- Wire breakage and earth leakage in the control circuits are detected.
- Cross-wire shorts between the control circuits are not detected.
- Category 3 – PL e to EN ISO 13849-1 possible.



The connection of magnetic safety switches to the SRB 201LC safety-monitoring module is only admitted when the requirements of the standard EN 60947-5-3 are observed.

As the technical data are regarded, the following minimum requirements must be met:

- switching capacity: min. 240 mW
- switching voltage: min. 24 VDC
- switching current: min. 10 mA



For example, the following safety sensors meet the requirements:

- BNS 36-02Z(G), BNS 36-02/01Z(G)
- BNS 260-02Z(G), BNS 260-02/01Z(G)



When sensors with LED are wired in the control circuit (protective circuit), the following rated operating voltage must be observed and respected:

- 24 VDC with a max. tolerance of  $-5\%/+20\%$
- 24 VAC with a max. tolerance of  $-5\%/+10\%$

Otherwise availability problems could occur, especially in series-wired sensors, where a voltage drop in the control circuit is triggered by LED's for instance.

**Dual-channel control of a safety-related (microprocessor-based) safety guards with p-type transistor outputs (e.g. electronic safety sensors or AOPD's) to IEC 61496-1 (Fig. 11)**

- Wire breakage and earth leakage in the control circuits are detected.
- Cross-wire shorts between the monitoring circuits are usually detected by the safety guards. The safety-monitoring module therefore is not equipped with a cross-wire short detection here.
- Category 3 – PL e to EN ISO 13849-1 possible.
- If cross-wire shorts in the control circuits are detected by the safety guard: Control category 4 – PL e to EN ISO 13849-1 possible.

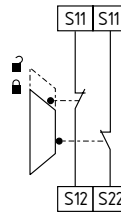

Fig. 9

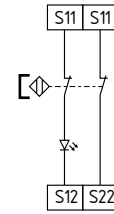

Fig. 10

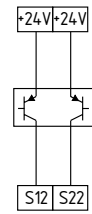

Fig. 11

8.4 Actuator configuration

**Single-channel control with feedback circuit (Fig. 12)**

- Suitable for increase in capacity or number of contacts by means of contactors or relays with positive-guided contacts.
- $\text{⊕}$  = feedback circuit: If the feedback circuit is not required, establish a bridge.

**Dual-channel control with feedback circuit (see Fig. 13)**

- Suitable for increase in capacity or number of contacts by means of contactors or relays with positive-guided contacts.
- $\text{⊕}$  = feedback circuit: If the feedback circuit is not required, establish a bridge.

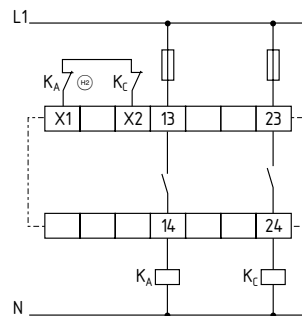

Fig. 12

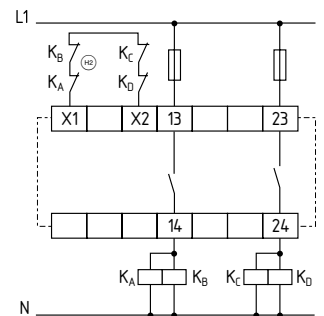

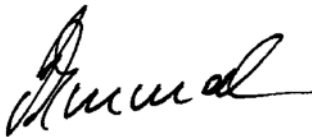

Fig. 13

9. EU Declaration of conformity

EU Declaration of conformity		 <b>SCHMERSAL</b>
Original	K.A. Schmersal GmbH & Co. KG Möddinghofe 30 42279 Wuppertal Germany Internet: www.schmersal.com	
We hereby certify that the hereafter described components both in their basic design and construction conform to the applicable European Directives.		
<b>Name of the component:</b>	SRB201LC	
<b>Description of the component:</b>	Safety-monitoring module for emergency stop circuits, guard door monitoring, magnetic safety switches and AOPD's	
<b>Relevant Directives:</b>	Machinery Directive EMC-Directive RoHS-Directive	2006/42/EC 2014/30/EU 2011/65/EU
<b>Applied standards:</b>	EN 60947-5-3:2013 EN 50178:1997 EN ISO 13849-1:2015 IEC 61508 parts 1 to 7:2010	
<b>Notified body for the prototype test:</b>	TÜV Rheinland Industrie Service GmbH Am Grauen Stein, 51105 Köln ID n°: 0035	
<b>EC-prototype test certificate:</b>	01/205/0734.02/20	
<b>Person authorised for the compilation of the technical documentation:</b>	Oliver Wacker Möddinghofe 30 42279 Wuppertal	
<b>Place and date of issue:</b>	Wuppertal, November 16, 2020	
SRB201LC-F-EN		
	Authorised signature <b>Philip Schmersal</b> Managing Director	



The currently valid declaration of conformity can be downloaded from the internet at [products.schmersal.com](http://products.schmersal.com).

