



EN Operating instructions.pages 1 to 4
Original

Content

1 About this document

1.1 Function 1

1.2 Target group: authorised qualified personnel. 1

1.3 Explanation of the symbols used 1

1.4 Appropriate use 1

1.5 General safety instructions 1

1.6 Warning about misuse 2

1.7 Exclusion of liability 2

2 Product description

2.1 Ordering code 2

2.2 Special versions. 2

2.3 Purpose 2

2.4 Technical data 2

2.5 Classification 2

3 Mounting

3.1 General mounting instructions 3

3.2 Dimensions 3

4 Electrical connection

4.1 General information for electrical connection. 3

5 Operating principle and settings

5.1 Operating principle after the operating voltage is switched on 3

6 Set-up and maintenance

6.1 Functional testing. 3

6.2 Maintenance 3

7 Disassembly and disposal

7.1 Disassembly. 3

7.2 Disposal 3

8 Appendix

8.1 Wiring examples 3

9 EU Declaration of conformity

1. About this document

1.1 Function

This operating instructions manual provides all the information you need for the mounting, set-up and commissioning for the safe operation and disassembly of the safety-monitoring module. The operating instructions must be available in a legible condition and a complete version in the vicinity of the device.

1.2 Target group: authorised qualified personnel

All operations described in this operating instructions manual must be carried out by trained specialist personnel, authorised by the plant operator only.

Please make sure that you have read and understood these operating instructions and that you know all applicable legislations regarding occupational safety and accident prevention prior to installation and putting the component into operation.

The machine builder must carefully select the harmonised standards to be complied with as well as other technical specifications for the selection, mounting and integration of the components.

1.3 Explanation of the symbols used



Information, hint, note:

This symbol is used for identifying useful additional information.



Caution: Failure to comply with this warning notice could lead to failures or malfunctions.

Warning: Failure to comply with this warning notice could lead to physical injury and/or damage to the machine.

1.4 Appropriate use

Products in Schmersal's range are not intended to be used by private end consumers.

The products described in these operating instructions are developed to execute safety-related functions as part of an entire plant or machine. It is the responsibility of the manufacturer of a machine or plant to ensure the correct functionality of the entire machine or plant.

The safety-monitoring module must be exclusively used in accordance with the versions listed below or for the applications authorised by the manufacturer. Detailed information regarding the range of applications can be found in the chapter "Product description".

1.5 General safety instructions

The user must observe the safety instructions in this operating instructions manual, the country specific installation standards as well as all prevailing safety regulations and accident prevention rules.



Further technical information can be found in the Schmersal catalogues or in the online catalogue on the Internet: products.schmersal.com.

The information contained in this operating instructions manual is provided without liability and is subject to technical modifications.

There are no residual risks, provided that the safety instructions as well as the instructions regarding mounting, commissioning, operation and maintenance are observed.

1.6 Warning about misuse



In case of inadequate or improper use or manipulations of the safety-monitoring module, personal hazards or damages to machinery or plant components cannot be excluded. The relevant requirements of the standard EN ISO 14119 must be observed.

1.7 Exclusion of liability

We shall accept no liability for damages and malfunctions resulting from defective mounting or failure to comply with this operating instructions manual. The manufacturer shall accept no liability for damages resulting from the use of unauthorised spare parts or accessories.

For safety reasons, invasive work on the device as well as arbitrary repairs, conversions and modifications to the device are strictly forbidden; the manufacturer shall accept no liability for damages resulting from such invasive work, arbitrary repairs, conversions and/or modifications to the device.

2. Product description

2.1 Ordering code

This operating instructions manual applies to the following types:

AES 7112.①

No.	Option	Description
①	1	110 VAC
	2	230 VAC
	3	24 VAC



Only if the information described in this operating instructions manual are realised correctly, the safety function and therefore the compliance with the Machinery Directive is maintained.

2.2 Special versions

For special versions, which are not listed in the order code below 2.1, these specifications apply accordingly, provided that they correspond to the standard version.

2.3 Purpose

The safety-monitoring modules for integration in safety circuits are designed for fitting in control cabinets. They are used for the safe evaluation of the signals of positive break position switches for safety functions or magnetic safety sensors on sliding, hinged and removable safety guards as well as emergency stop control devices.

Design

The AES 7112 has a triple redundant structure for monitoring guard doors. A first fault can lead to a failure of one of the three channels, whereby the two other channels maintain their safe function. In this system "position switches for safety functions", the requirements of IEC 60947-5-3 are only met, when the combination of safety sensor and coded magnet plus safety-monitoring module is used. A safety sensor alone does not meet the requirements of this standard.



The entire concept of the control system, in which the safety component is integrated, must be validated to the relevant standards.

2.4 Technical data

Standards: EN 60204-1, EN 60947-5-3, EN ISO 13849-1, IEC 61508

Start conditions: Automatic
 Feedback circuit available: no
 Start-up test: no
 Drop-out delay in case of "emergency stop": < 50 ms
 Rated operating voltage U_e : AES 7112.1: 110 VAC
 AES 7112.2: 230 VAC
 AES 7112.3: 24 VAC

Rated operating current I_e : 0.2 A
 Rated insulation voltage U_i : 250 V
 Rated impulse withstand voltage U_{imp} : 4.8 kV
 Thermal test current I_{the} : 5 A
 Internal electronic fuse: no
 Power consumption: 2.5 W

Inputs monit:

Cross-wire short detection: yes
 Wire breakage detection: yes
 Earth connection detection: no
 Number of NC contacts: 2x 2NC
 Number of NO contacts: 2x 2NO

Outputs:

Stop category 0: 1
 Stop category 1: 0
 Number of safety contacts: 1
 Number of auxiliary contacts: 0
 Number of signalling outputs: 0

Switching capacity of the safety contacts: max. 250 VAC, max 5 A, ohmic, inductive only in case of appropriate interference suppression

Utilisation category to EN 60947-5-1: AC-15: 250 V / 2 A
 DC-13: 24 V / 2 A

Max. fuse rating: 5 A gG D-fuse
 Mechanical life: > 50 million operations
 LED display: Release

Ambient conditions:

Operating temperature: 0 °C ... +55 °C
 Storage and transport temperature: -25 °C ... +70 °C
 Degree of protection: Enclosure: IP40
 Terminals: IP20
 Clearance: IP54

Degree of pollution: 2
 Mounting: snaps onto standard rail to EN 60715
 Connection type: Screw connection
 Min. cable section: 0.25 mm²
 Max. Cable section: 1.5 mm², solid strand or multi-strand lead (including conductor ferrules)

Tightening torque: 0.3 Nm
 Max. cable length: 100 m of 0.75 mm² conductor
 Weight: AES 7112.1: 180 g
 AES 7112.2: 180 g
 AES 7112.3: 135 g

2.5 Classification

Standards: EN ISO 13849-1
 PL: up to c
 Control category: up to 1
 PFH-value: 1.14 x 10⁻⁶ / h

Applicable for applications with up to max. 50,000 switching cycles / year and max. 80 % contact load. Diverging applications upon request.

Service life: 20 years

3. Mounting

3.1 General mounting instructions

Mounting: snaps onto standard rails to EN 60715.



To avoid EMC disturbances, the physical ambient and operational conditions at the place where the product is installed, must meet the provisions laid down in the paragraph "Electromagnetic Compatibility (EMC)" of EN 60204-1.

3.2 Dimensions

Device dimensions (H/W/D): 105 x 96 x 58 mm

4. Electrical connection

4.1 General information for electrical connection



The electrical connection may only be carried out by authorised personnel in a de-energised condition.



As far as the electrical safety is concerned, the protection against unintentional contact of the connected and therefore electrically interconnected apparatus and the insulation of the feed cables must be designed for the highest voltage, which can occur in the device.

Settle length x of the conductor: 7 mm



Wiring examples: see appendix

5. Operating principle and settings

5.1 Operating principle after the operating voltage is switched on

If the safety guard is closed or the emergency stop button released, the enabling paths of the safety-monitoring module will close. The LED is green.

Inputs S14/S22/S32

Outputs

Enabling path 13-14:NO contact for safety functions

6. Set-up and maintenance

6.1 Functional testing

The safety function of the safety-monitoring module must be tested. The following conditions must be previously checked and met:

1. Correct fitting of the safety-monitoring module
2. Fitting and integrity of the power cable

6.2 Maintenance

In the case of correct installation and adequate use, the safety-monitoring module features maintenance-free functionality. A regular visual inspection and functional test, including the following steps, is recommended:

- Check the correct fixing of the safety monitoring module
- Check the cable for damage.



The device has to be integrated into the periodic check-ups according to the Ordinance on Industrial Safety and Health, however at least 1x/year.

Damaged or defective components must be replaced.

7. Disassembly and disposal

7.1 Disassembly

The safety monitoring module must be disassembled in the de-energised condition only.

7.2 Disposal

The safety monitoring module must be disposed of in an appropriate manner in accordance with the national prescriptions and legislations.

8. Appendix

8.1 Wiring examples

The application examples shown are suggestions. They however do not release the user from carefully checking whether the switchgear and its set-up are suitable for the individual application.

The wiring diagram is shown with guard doors closed and in a de-energised condition. Inductive loads (e.g. contactors, relays, etc.) are to be provided with suitable interference suppression circuitry. Do not connect additional loads to terminal S..

Guard door monitoring by means of a magnetic safety sensor (BNS)

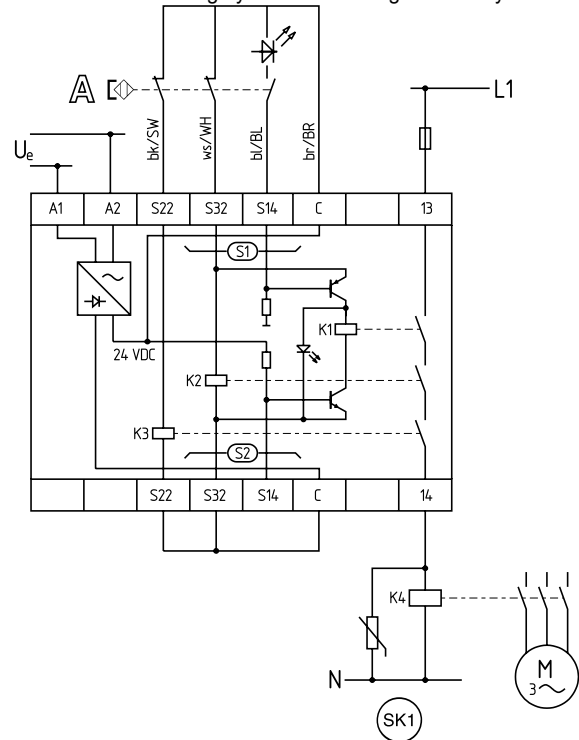

Key

A Non-contact sensor

9. EU Declaration of conformity

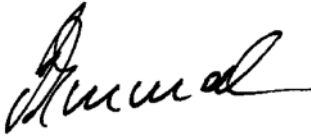
EU Declaration of conformity		
Original	K.A. Schmersal GmbH & Co. KG Möddinghofe 30 42279 Wuppertal Germany Internet: www.schmersal.com	
We hereby certify that the hereafter described components both in their basic design and construction conform to the applicable European Directives.		
Name of the component:	AES 7112 ¹⁾ , AES 7112.3-2261 ²⁾	
Type:	See ordering code	
Description of the component:	Safety-monitoring module for non-contact safety switches and safety relay combination in connection with the BNS series magnetic safety switches	
Relevant Directives:	Machinery Directive	2006/42/EC
	EMC-Directive	2014/30/EU
	RoHS-Directive	2011/65/EU
Applied standards:	EN 60947-5-3:2013 EN ISO 13849-1:2015 EN ISO 13849-2:2012	
Notified body, which approved the full quality assurance system, referred to in Appendix X, 2006/42/EC:	TÜV Rheinland Industrie Service GmbH Am Grauen Stein, 51105 Köln Kenn-Nr.: 0035	
Person authorised for the compilation of the technical documentation:	Oliver Wacker Möddinghofe 30 42279 Wuppertal	
Place and date of issue:	Wuppertal, December 16, 2021	
		
	Authorised signature Philip Schmersal Managing Director	

AES7112-E-EN



The currently valid declaration of conformity can be downloaded from the internet at products.schmersal.com.

