



**EN** Operating instructions. . . . .pages 1 to 6  
Original

**Content**

**1 About this document**

1.1 Function . . . . . 1

1.2 Target group: authorised qualified personnel. . . . . 1

1.3 Explanation of the symbols used . . . . . 1

1.4 Appropriate use . . . . . 1

1.5 General safety instructions . . . . . 1

1.6 Warning about misuse . . . . . 2

1.7 Exclusion of liability . . . . . 2

**2 Product description**

2.1 Ordering code . . . . . 2

2.2 Special versions. . . . . 2

2.3 Purpose . . . . . 2

2.4 Technical data . . . . . 2

2.5 Classification . . . . . 2

**3 Mounting**

3.1 General mounting instructions . . . . . 3

3.2 Dimensions . . . . . 3

3.3 Axial misalignment. . . . . 3

3.4 Adjustment. . . . . 4

**4 Electrical connection**

4.1 General information for electrical connection. . . . . 4

4.2 Contact variants. . . . . 4

4.3 Connector . . . . . 4

**5 Set-up and maintenance**

5.1 Functional testing. . . . . 5

5.2 Maintenance . . . . . 5

**6 Disassembly and disposal**

6.1 Disassembly. . . . . 5

6.2 Disposal. . . . . 5

**7 EU Declaration of conformity**

**1. About this document**

**1.1 Function**

This operating instructions manual provides all the information you need for the mounting, set-up and commissioning to ensure the safe operation and disassembly of the safety switchgear. The operating instructions must be available in a legible condition and a complete version in the vicinity of the device.

**1.2 Target group: authorised qualified personnel**

All operations described in this operating instructions manual must be carried out by trained specialist personnel, authorised by the plant operator only.

Please make sure that you have read and understood these operating instructions and that you know all applicable legislations regarding occupational safety and accident prevention prior to installation and putting the component into operation.

The machine builder must carefully select the harmonised standards to be complied with as well as other technical specifications for the selection, mounting and integration of the components.

**1.3 Explanation of the symbols used**



**Information, hint, note:**

This symbol is used for identifying useful additional information.



**Caution:** Failure to comply with this warning notice could lead to failures or malfunctions.

**Warning:** Failure to comply with this warning notice could lead to physical injury and/or damage to the machine.

**1.4 Appropriate use**

The Schmersal range of products is not intended for private consumers.

The products described in these operating instructions are developed to execute safety-related functions as part of an entire plant or machine. It is the responsibility of the manufacturer of a machine or plant to ensure the correct functionality of the entire machine or plant.

The safety switchgear must be exclusively used in accordance with the versions listed below or for the applications authorised by the manufacturer. Detailed information regarding the range of applications can be found in the chapter "Product description".

**1.5 General safety instructions**

The user must observe the safety instructions in this operating instructions manual, the country specific installation standards as well as all prevailing safety regulations and accident prevention rules.



Further technical information can be found in the Schmersal catalogues or in the online catalogue on the Internet: [products.schmersal.com](http://products.schmersal.com).

The information contained in this operating instructions manual is provided without liability and is subject to technical modifications.

There are no residual risks, provided that the safety instructions as well as the instructions regarding mounting, commissioning, operation and maintenance are observed.

### 1.6 Warning about misuse



In case of improper use or manipulation of the safety switchgear, personal hazards or damages to machinery or plant components cannot be excluded.

### 1.7 Exclusion of liability

We shall accept no liability for damages and malfunctions resulting from defective mounting or failure to comply with this operating instructions manual. The manufacturer shall accept no liability for damages resulting from the use of unauthorised spare parts or accessories.

For safety reasons, invasive work on the device as well as arbitrary repairs, conversions and modifications to the device are strictly forbidden; the manufacturer shall accept no liability for damages resulting from such invasive work, arbitrary repairs, conversions and/or modifications to the device.

## 2. Product description

### 2.1 Ordering code

This operating instructions manual applies to the following types:

**BNS 33-①Z②-③**

No.	Option	Description
①	11	1 NO / 1 NC
	12	1 NO / 2 NC
②		without LED
	G	with LED
③		Pre-wired cable
	ST	integrated connector

### 2.2 Special versions

For special versions, which are not listed in the order code below 2.1, these specifications apply accordingly, provided that they correspond to the standard version.

### 2.3 Purpose

The BNS 33 safety sensor is designed for application in safety circuits and is used for monitoring the position of movable safety guards to EN ISO 14119 and EN 60947-5-3. To actuate the safety sensors, only the BPS 33 actuators can be used, conventional magnets are not suitable.



The safety switchgears are classified according to EN ISO 14119 as type 4 interlocking devices.

The safety switches are used for applications, in which the hazardous situation is terminated without delay when the safety guard is opened.

Only the entire system consisting of the safety sensor (BNS 33), the actuator (BPS 33) and the safety-monitoring module (SRB) meets the requirements of the standard EN 60947-5-3.



The user must evaluate and design the safety chain in accordance with the relevant standards and the required safety level.



The entire concept of the control system, in which the safety component is integrated, must be validated to the relevant standards.

### 2.4 Technical data

Standards:	EN 60947-5-3, BG-GS-ET-14
Enclosure:	glass-fibre reinforced thermoplastic
Degree of protection:	IP67 to EN 60529
Termination:	Boflex cable or M8 connector
Connecting cable:	4 x 0.25 mm <sup>2</sup>
Version with integrated connector:	M8 x 1, 4-pole
Tightening torque for connectors:	max. 0.3 Nm
Operating principle:	magnetic
Actuator:	BPS 33, BPS 33-2326, coded
Coding level according to EN ISO 14119:	low
Switching distances to EN 60947-5-3:	
- Assured switching distance $s_{ao}$ :	5 mm (BPS 33); 8 mm (BPS 33-2326)
- Assured switch-off distance $s_{ar}$ :	15 mm (BPS 33); 18 mm (BPS 33-2326)
Switching condition indication:	LED only with ordering suffix G
Rated insulation voltage $U_i$ :	32 V
Rated impulse withstand voltage $U_{imp}$ :	0.8 kV
Switching voltage:	without LED: max. 100 VAC/DC with LED: max. 24 VDC with connector: max. 60 VAC/DC
Switching current:	without LED: max. 400 mA with LED: max. 10 mA
Switching capacity:	without LED: max. 10 W with LED: max. 240 mW
Required short-circuit current:	100 A
Ambient temperature:	-25 °C ... +70 °C
Storage and transport temperature:	-25 °C ... +70 °C
Max. switching frequency:	5 Hz
Resistance to shock:	30 g / 11 ms
Resistance to vibration:	10 ... 55 Hz, amplitude 1 mm



Same Polarity.

### 2.5 Classification

Standards:	EN ISO 13849-1
Safety contacts:	
- NC / NC combination:	S21-S22 and S11-S12 or C-S22 and C-S12
- NC / NO combination:	S21-S22 and S13-S14 or C-S22 and C-S14
Intended structure:	
- 2-channel usage:	usable to cat. 4 / PL e with suitable logic unit
$B_{10D}$ NC contacts at 20 % contact load:	25.000.000
$B_{10D}$ NO contacts at 20 % contact load:	25.000.000
Mission time:	20 years

$$MTTF_D = \frac{B_{10D}}{0,1 \times n_{op}} \quad n_{op} = \frac{d_{op} \times h_{op} \times 3600 \text{ s/h}}{t_{cycle}}$$

(Determined values can vary depending on the application-specific parameters  $h_{op}$ ,  $d_{op}$  and  $t_{cycle}$  as well as the load.)

If multiple safety components are wired in series, the Performance Level to EN ISO 13849-1 will be reduced due to the restricted error detection under certain circumstances.

### 3. Mounting

#### 3.1 General mounting instructions



During fitting, the requirements of EN ISO 14119 must be observed.

- Fitting is only authorised in a de-energised condition
- Do not use the sensor and the actuator as a mechanical backstop
- Ensure the safety sensor is mounted on a flat surfaces to avoid tensile stresses that could damage the sensor or lead to varying switching distances
- Do not install the safety sensor and the actuator in strong magnetic fields
- If possible, do not mount the sensor and the actuator on ferromagnetic material. Otherwise, the following variations of the switching distances may be expected: A distance of 0...5 mm from the mounting surface to the ferromagnetic material: switching distance is only approx. 40 % of the original switching distance; A distance of 5...8 mm: approx. 80 % of the original switching distance; > 10 mm: no change (use spacer BN 31/33)
- Do not subject the safety sensor and actuator to extreme vibrations and shocks.
- Keep away from metal chips
- The mounting distance between two sensors should always be at least 50 mm.



The actuator must be permanently fitted to the safety guards and protected against displacement by suitable measures (tamperproof screws, gluing, drilling of the screw heads).

#### 3.2 Dimensions

All measurements in mm.

##### Safety sensor with cable

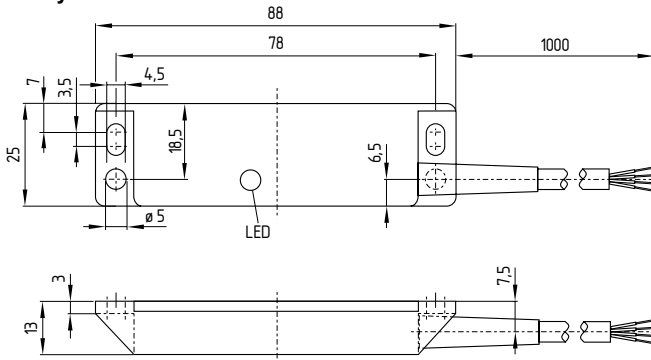

##### Safety sensor with connector

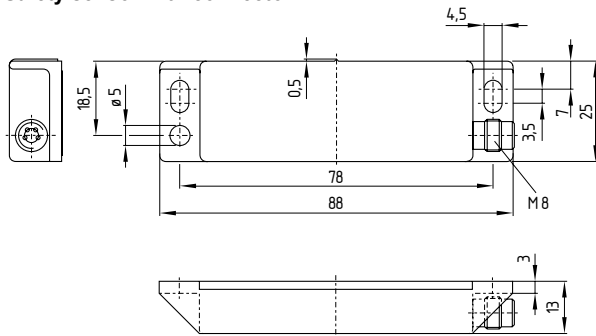

##### Actuator

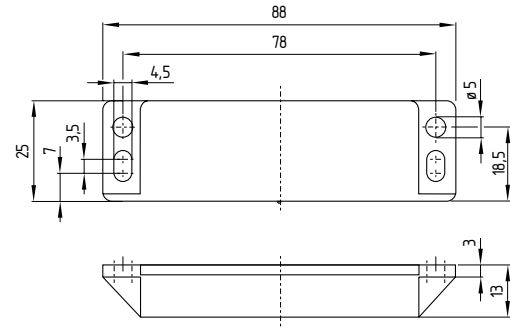

##### Spacer

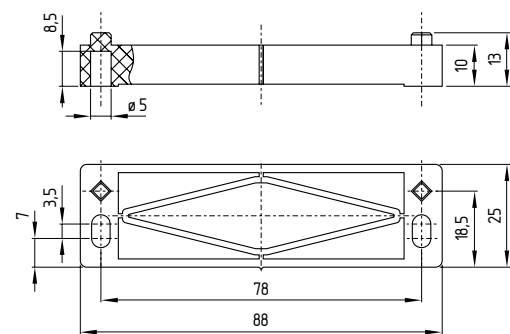

#### 3.3 Axial misalignment

A horizontal and vertical misalignment of the safety sensor and the actuator is tolerated. The possible misalignment depends on the distance of the active surfaces of the sensor and the actuator. The sensor remains active within the tolerance range.

The specified switching distances refer to opposedly mounted safety sensors and actuators. Different arrangements are possible, however this may lead to different switching distances.

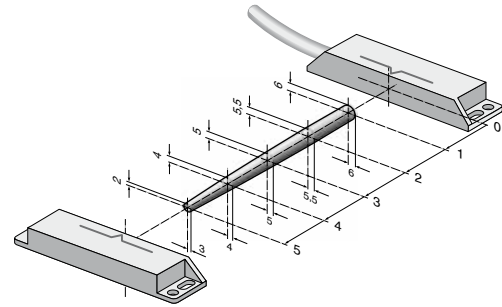

- assured switching distance:  $s_{ao} = 5 \text{ mm}$   
 8 mm (Ordering suffix -2326)
- assured switch-off distance:  $s_{ar} = 15 \text{ mm}$   
 18 mm (Ordering suffix -2326)

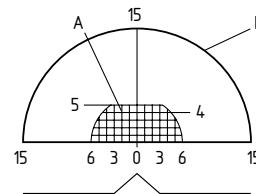

#### Key

- A Base position area (sensor actuated, release)
- B Switch-off area (at the latest at this point, all Reed contacts are not actuated)

### 3.4 Adjustment

If the central marking of the actuator is within the represented base position area, a release signal is given at the connected safety-monitoring module.



#### Recommended Adjustment

Align the safety sensor and actuator at a distance of  $0.5 \times s_{a0}$ .

Since under certain operational circumstances or due to tolerances, the case may happen that both outputs in the safety sensor do not operate exactly simultaneously, the LED cannot be the only criterion for a correct adjustment. The correct functionality must always be checked by means of the connected safety-monitoring module.

## 4. Electrical connection

### 4.1 General information for electrical connection



The electrical connection may only be carried out by authorised personnel in a de-energised condition.

The safety sensors must be wired in accordance with the wire colours or the pin configuration.

Cross-wire detection in the safety-monitoring module is not possible for safety sensors of versions -12 (1 NO contact / 2 NC contacts).

### 4.2 Contact variants

The contact position shows the actuated sensor function when the safety guard is closed. If the safety sensor is equipped with a LED, the LED will be illuminated when the guard is open.

Safety contacts: S21-S22 and S11-S12 or S13-S14  
oder C-S22 and C-S12 or C-S14  
Signalling contact: S31-S32 or C-S32

The numbers between brackets indicate the PIN configuration of the versions with integrated connector; indication of the wire colours for the version with cable.

#### BNS 33-11Z

BNS 33-11Z-2063

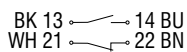

#### BNS 33-11ZG

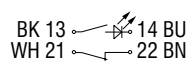

#### BNS 33-12Z

BNS 33-12Z-2063

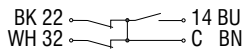

#### BNS 33-12ZG

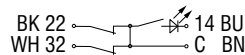

#### BNS 33-11ZST

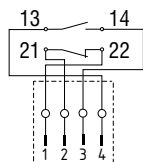

#### BNS 33-11ZSTG

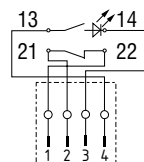

#### BNS 33-12ZST

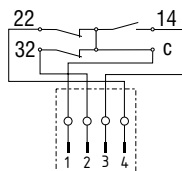

#### BNS 33-12ZSTG

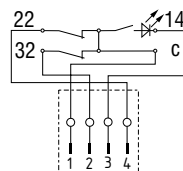

Information for the selection of suitable safety-monitoring modules can be found in the Schmersal catalogues or in the online catalogue on the Internet: [products.schmersal.com](http://products.schmersal.com).

Connecting multiple BNS 36-11Z safety sensors to one safety-monitoring module is technically possible. To connect multiple safety sensors (check if authorised!), their NO contacts are wired in parallel and their NC contacts in series. The Protect-IE-11 or -02 or PROTECT-PE-11(-AN) or -02 input expander module can be used to connect up to 4 safety sensors with NC/NC or NC/NO contacts.

Safety sensors equipped with LED's shall not be wired in series, except for the Protect-IE or PROTECT-PE input expander module. As a result of this, the luminosity of the LED's would considerably decrease and the voltage could drop below the minimum input voltage of the downstream safety-monitoring module.

### 4.3 Connector

#### Integrated connector M8, 4-pole

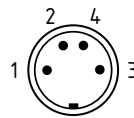

#### Accessories: connecting cable with coupling

M8, 4-pole, PUR, screw terminal		2 m	5 m	10 m	
	1 BN	straight	103011340	103007356	-
	2 WH				
	3 BU	angled	103011348	103011349	-
	4 BK				

8 mm, 4-pole, PVC, cage clamps		2 m	5 m	10 m	
	1 BN	straight	103011341	103011342	103011343
	2 WH				
	3 BU	angled	103011344	103011345	103011346
	4 BK				

#### Accessory: Y-adapter BNS-Y-11 (Ordering code 101194059)

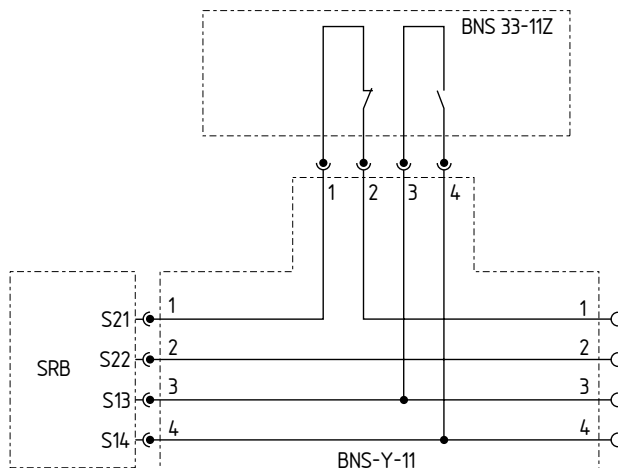

### 5. Set-up and maintenance

#### 5.1 Functional testing

The safety function of the safety components must be tested. The following conditions must be previously checked and met:

1. Fitting of the sensor and the actuator.
2. Fitting and integrity of the power cable.
3. The system is free of dirt and soiling (in particular metal chips).

#### 5.2 Maintenance

In the case of correct installation and adequate use, the safety sensor features maintenance-free functionality.

A regular visual inspection and functional test, including the following steps, is recommended:

- Check of the safety function
- Check the fitting of the sensor and the actuator.
- Remove possible metal chips.
- Check the cable for damage.



Adequate measures must be taken to ensure protection against tampering either to prevent tampering of the safety guard, for instance by means of replacement actuators.

**Damaged or defective components must be replaced.**

### 6. Disassembly and disposal

#### 6.1 Disassembly

The safety switchgear must be disassembled in a de-energised condition only.

#### 6.2 Disposal

The safety switchgear must be disposed of in an appropriate manner in accordance with the national prescriptions and legislations.

7. EU Declaration of conformity

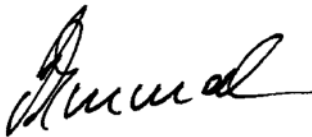
<b>EU Declaration of conformity</b>		
Original	K.A. Schmersal GmbH & Co. KG Möddinghofe 30 42279 Wuppertal Germany Internet: www.schmersal.com	
We hereby certify that the hereafter described components both in their basic design and construction conform to the applicable European Directives.		
<b>Name of the component:</b>	BNS 33	
<b>Type:</b>	See ordering code	
<b>Description of the component:</b>	Coded safety-sensor with magnetic operating principle in combination with the SRB(-E) / PROTECT-SELECT / PSC1 safety-monitoring modules from Schmersal or an equivalent safety-oriented control system fulfilling the requirements of the EN 60947-5-3.	
<b>Relevant Directives:</b>	2006/42/EC    Machinery Directive 2011/65/EU    RoHS-Directive	
<b>Applied standards:</b>	EN 60947-5-3:2013 EN ISO 14119:2013	
<b>Person authorised for the compilation of the technical documentation:</b>	Oliver Wacker Möddinghofe 30 42279 Wuppertal	
<b>Place and date of issue:</b>	Wuppertal, November 15, 2022	
BNS33-G-EN		
	Authorised signature <b>Philip Schmersal</b> Managing Director	



The currently valid declaration of conformity can be downloaded from the internet at [products.schmersal.com](http://products.schmersal.com).

