



EN Operating instructions page 1
Original

Destination and use

The actuators are preferably used on safety guards in conjunction with the AZ 17 safety switches or AZM 170 solenoid interlocks.

There are different actuator types available. The actuators AZ 17/170-B1, -B5, -B11 and -B15 are preferably used for sliding and removable safety guards. For hinged guards, the AZ 17-B6, AZM 170-B6, AZ 17i/170i-B6R and -B6L actuator.

Mounting instructions

When the switch is fitted on a hinged safety guard, please ensure that the point of rotation is located within the range of the upper surface of the safety switch, in which the actuator hook is inserted (refer to table).

i Use tamper-proof screws to prevent unauthorised removal of the switch; these screws are available as an accessory. Please observe that, when fixing the switch e.g. by means of rivetting or welding, the insertion depth of the actuator is not modified.

Actuating radii					
		R _{min} [mm]	d [mm]	R _{min} [mm]	d [mm]
	AZ 17-B6	50	11	50	11
	AZ 17i/170i-B6L	50	11	50	11
	AZ 17i/170i-B6R	50	11	50	11
	AZM 170-B6	50	11	50	11
	AZ 17/170-B1				
	AZ 17/170-B1-2245				
	AZ 17/170-B5				
	AZ 17/170-B11				
	AZ 17/170-B15				

Key

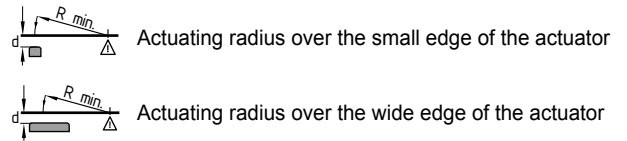

The axis of the hinge must be d mm above and in a parallel plane to the top surface of the safety switch. The basis setting provides a minimum radius of R_{min}.

i **Setting screw**
To increase the radius, the setting screws a + b (-B6) must be turned by means of a hexagonal key A/F 2.5 mm.

Setting screw

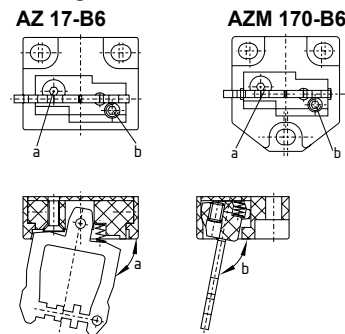

i **AZ 17/170-B1-2245 with rubber mountings**
Max. 200 Ncm tightening torque for mounting the actuator.



K. A. Schmersal GmbH & Co. KG
Industrielle Sicherheitssysteme
Mödinghofe 30, D - 42279 Wuppertal
Postfach 24 02 63, D - 42232 Wuppertal

Phone: +49 - (0)2 02 - 64 74 - 0
Telefax: +49 - (0)2 02 - 64 74 - 1 00
E-Mail: info@schmersal.com
Internet: http://www.schmersal.com