

# BL20 Economy Module

## 8 2-wire Analog Inputs U/I resp. 4 2/3-wire PT/NI Inputs

### BL20-E-8AI-U/I-4PT/NI

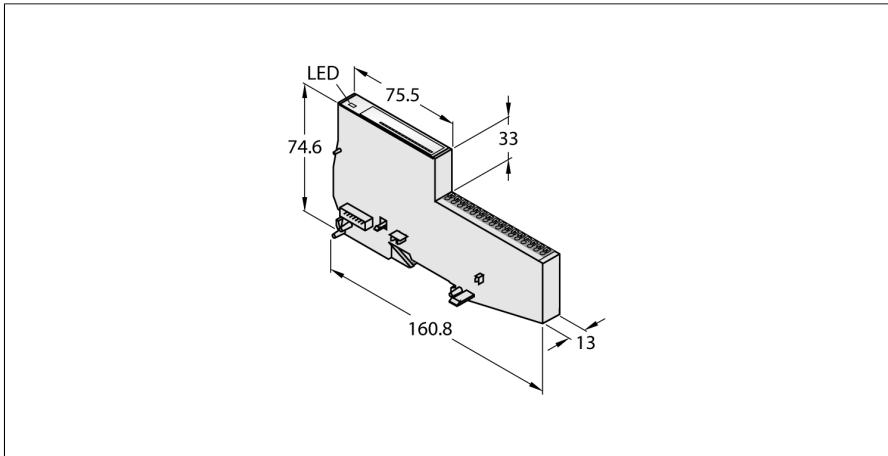

- Fieldbus-independent
- Electronics and connection technology in one housing
- Connectivity: Push-in terminals
- Protection class IP20
- LEDs indicate status and diagnostic
- Electronics galvanically separated from the field level via optocouplers
- 8 analog 2-wire inputs U/I
- Passive input - External supply
- 0 ... 20 mA, 4 ... 20 mA, -10 ... +10 VDC or 0 ... +10 VDC, selectable per channel
- Alternatively: 4PT/NI inputs (always 2 analog inputs are combined to a PT/Ni 2/3-wire input)

Type	BL20-E-8AI-U/I-4PT/NI
ID	6827325

Number of channels	8/4
Rated voltage from the supply terminal	24 VDC
Admissible range	18...30 VDC
Nominal current from field supply	≤ 35 mA
Nominal current from module bus	≤ 35 mA
Power dissipation, typical	≤ 1.5 W

<b>Inputs</b>	
Input type	0/4...20 mA, -10/0...10 VDC, Pt100, Pt200, Pt500, Pt1000, NI100, NI1000, 0...250 Ω, 0...400 Ω, 0...800 Ω, 0...2000 Ω, 0...4000 Ω
Input resistance	< 62 Ω (current) resp. > 98.5 kΩ (voltage)
Max. input current	current: 50 mA
Max. input voltage	Voltage: -20 VDC < U < 20 VDC
Electrical isolation	electronics for the field level
Output connectivity	Push-in

Maximum limiting frequency analog	1.5 Hz
Basic fault limit at 23 °C	< 0.2 %
Temperature coefficient	< 200 ppm/°C of full scale
Resolution	16 Bit
Measured-value display	16 bit signed integer
	12 bit full range left-justified
	12 bit left-justified
Conversion time	< (44 x [ number of actively parametrized channels]) ms

Number of diagnostics bytes	8
Number of parameter bytes	8

#### Functional principle

Electronics and connection technology are integrated in the housing. A base module is not needed. Economy modules and modules with separate electronics and connection technology can be fitted into a station, provided the base modules feature tension spring connections.

The use of gateways makes economy modules completely independent from the higher level fieldbus.

Dimensions (W x L x H)	13 x 160.8 x 74.6 mm
Approvals	CE, cULus, zone 2, Class I, Div. 2
Ambient temperature	0...+55 °C
Storage temperature	-25...+85 °C
Relative humidity	15...95 %, no condensation allowed
Vibration test	Acc. to EN 61131
Shock test	Acc. to IEC 60068-2-27
Drop and topple	acc. to IEC 68-2-31 and free fall to IEC 68-2-32
Electromagnetic compatibility	Acc. to EN 50082-2
Protection class	IP20
MTTF	229 years acc. to SN 29500 (Ed. 99) 20 °C

## Terminal assignment



### Analog Inputs

The pin assignment is dependent on the sensor type. Examples of the most common 2- and 4-wire sensors with electric current or voltage signal are listed below.

**Note:** Open inputs and/or unused channels should not be programmed in the Pt/Ni or resistance (R) mode, because this may lead to minor measurement errors at adjacent channels. However, if this is necessary, the affected channels must be terminated with a resistance. Thereby the resistance value must be in the programmed measuring range.

### Pin Assignment

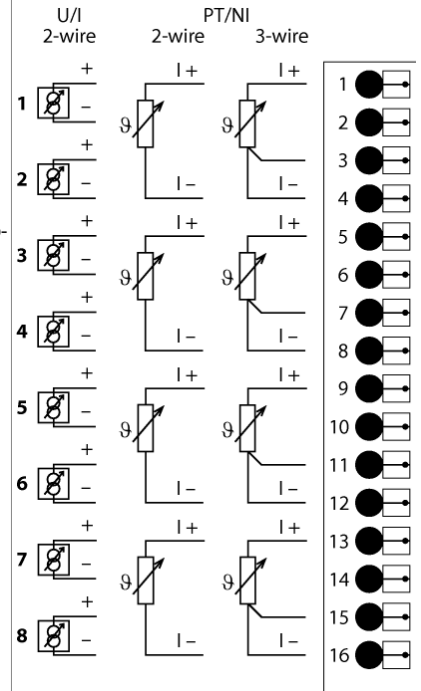

### 4-wire sensor (U/I)

The sensor and the BL20  $U_L$  fuse are fed from a common source. The sensor and the BL20  $U_L$  fuse are automatically on the same GND potential.

### Pin Assignment

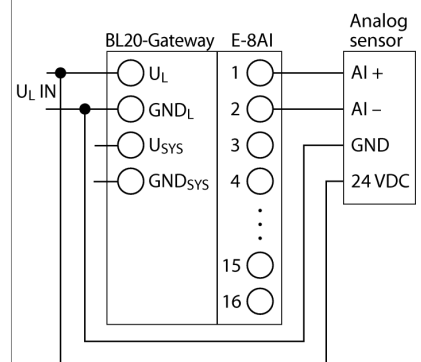

### 4-wire sensor (U/I)

The sensor and the BL20  $U_L$  are fed from different sources.  $U_L$  of the BL20 system and AI of the sensor must be on the same GND-potential. For this,  $U_L$  and AI must be bridged.

### Pin Assignment

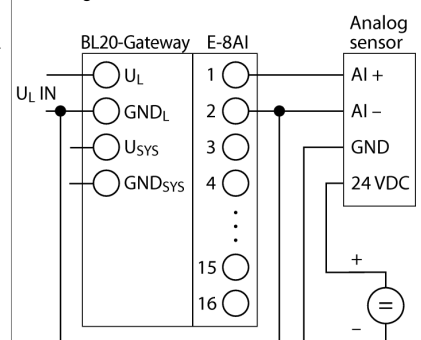

**2-wire sensor (U/I)**

The sensor and the BL20 U<sub>L</sub> fuse are fed from a common source.  
The sensor and the BL20 U<sub>L</sub> fuse are automatically on the same GND potential.

**Pin Assignment**