

Q106E

Photoelectric Sensor – Opposed Mode Sensor (Emitter)

Miniature Sensor

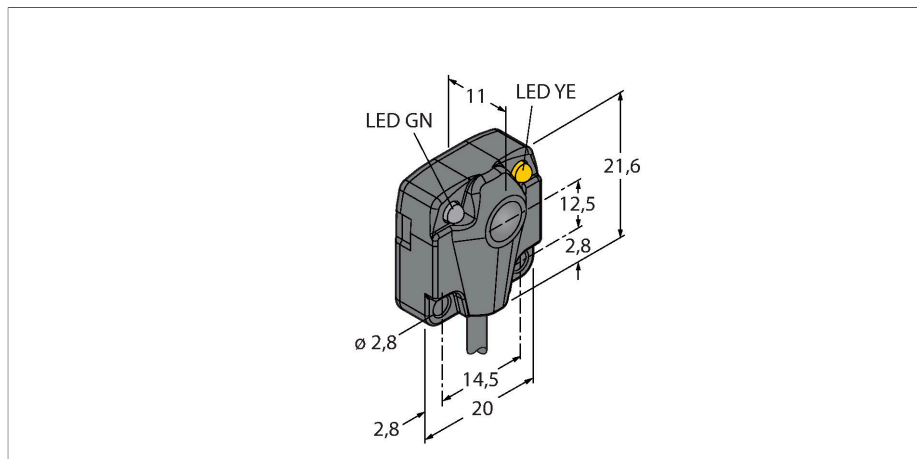

Features

- Cable, 2 m
- Protection class IP67
- Glass lens
- Operating voltage: 10...30 VDC

Wiring diagram

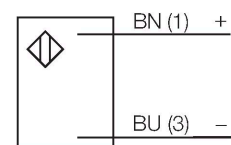

Technical data

Type	Q106E
ID no.	3044756
Optical data	
Function	Opposed mode sensor
Operating mode	Emitter
Light type	IR
Wavelength	880 nm
Range	0...1800 mm
Electrical data	
Operating voltage	10...30 VDC
Residual ripple	< 10 % U_{ss}
DC rated operational current	≤ 150 mA
No-load current	≤ 15 mA
Short-circuit protection	yes / Cyclic
Reverse polarity protection	yes
Switching frequency	0.083 kHz
Readiness delay	≤ 0 ms
Response time typical	< 8 ms
Overcurrent release	> 220 mA
Mechanical data	
Design	Rectangular, Q10
Dimensions	21.6 x 20 x 10 mm
Housing material	Plastic, Thermoplastic material, Black
Lens	glass, Glass
Electrical connection	Cable, 2 m, PVC
Number of cores	2

Functional principle

Opposed mode sensors consist of an emitter and a receiver. They are installed opposite to each other whereby the emitted light aims directly at the receiver. When an object interrupts or weakens the light beam, the sensor switches. Opposed mode sensors are the most reliable photoelectric sensors for detection of opaque objects. The excellent light/dark contrast and the very high excess gain are typical for this function mode and enable operation over large distances and under difficult conditions.

Excess gain curve
Excess gain in relation to distance

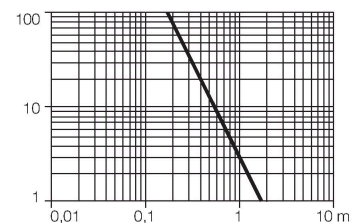

Technical data

Core cross-section	0.8 mm ²
Ambient temperature	-40...+70 °C
Protection class	IP67
Power-on indication	LED, Green
Switching state	LED, Yellow
Error indication	LED, green, Flashing
Excess gain indication	LED
Alarm display	LED yellow Flashing
Tests/approvals	