

Frequency Transducer/Pulse Counter 1-channel IM12-FI01-1SF-111R-CPR/24VDC/CC

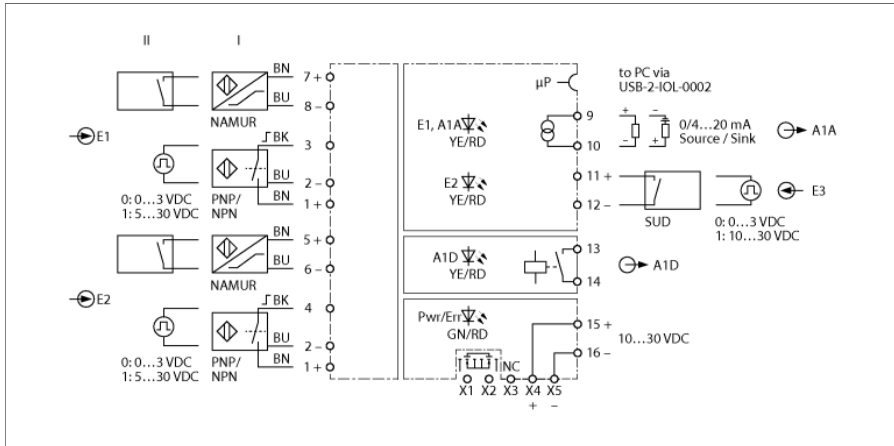

The frequency transducer/pulse counter IM12-FI01-1SF-111R-CPR/24VDC/CC transmits frequency signals up to 20,000 Hz galvanically isolated. In addition, limits, slip or clockwise/counter-clockwise rotation can be monitored. The devices are suitable for operation in zone 2.

The 1-channel device is equipped with two inputs for the connection of sensors acc. to EN 60947-5-6 (NAMUR) or potential-free contacts. On the output side, there is a 0/4...20 mA current output and a normally open relay. The device can be powered from a power bridge that also transmits a collective fault signal.

The device is parameterized via FDT and IODD with a PC. The current output can be set to 0/4...20 mA (source or sink optional). In accordance with the parameterization (I1, I2, I1 - I2 or I2 - I1), the input signals are output as a 0/4...20 mA normalized current signal. The normally open relay facilitates the monitoring of set limits for exceedance/shortfall and monitoring using a window function. The start-up bypass (SUD) is activated via input I1, I2 or I3.

The devices have a green power LED (Pwr) and a red LED to indicate internal faults. For the input circuit, a yellow and red status LED is available. A fault in the input circuit leads to a flashing red LED according to NE44, an internal error to a steady red LED. The fault current can be adjusted to < 3.5 mA or > 21.5 mA. A yellow LED indicates the switching state of the limit value relay. A yellow LED indicates that the start-up bypass is turned on.

The device can be used in safety circuits up to SIL2 (high and low demand according to IEC 61508) and meets the requirements of NE21. It is equipped with removable spring type terminals.

The device is equipped with removable spring-type terminals.

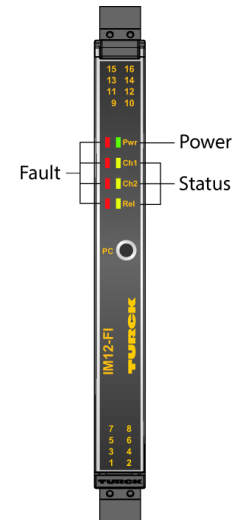

- Input circuits monitored for wire-break and short-circuit
- Parameterized via PC
- Complete galvanic isolation
- Removable spring type terminals
- Power bridge (connector incl. in delivery)
- ATEX use in Zone 2, cUL
- SIL 2

Dimensions

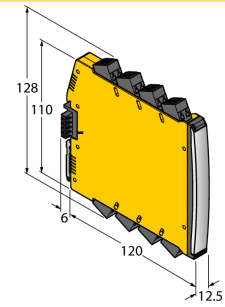

Type	IM12-FI01-1SF-111R-CPR/24VDC/CC
ID	7580226
Nominal voltage	24 VDC
Operating voltage	10...30 VDC
Power consumption	≤ 3 W
Power dissipation, typical	≤ 1.7 W
Monitoring range/Setting range	≤ 0.0006...1200000 min ⁻¹
NAMUR input	
NAMUR	EN 60947-5-6
No-load voltage	8.2 VDC
Short-circuit current	8.2 mA
Input resistance	1 kΩ
Cable resistance	≤ 50 Ω
Switch-on threshold	1.75 mA
Switch-off threshold	1.55 mA
Wire breakage threshold	≤ 0.06 mA
Short-circuit threshold	≥ 6.4 mA
3-wire input	
No-load voltage	12 VDC
0-signal	0...3VDC
1-signal	5...30 VDC
External signal source	
0-signal	0...3 VDC
1-signal	5...30 VDC
Output circuits	
Output current	Source/sink (10...30 V) 0/4...20 mA
Load resistance current output	≤ 0.8 kΩ
Output circuits (digital)	1 x relay (change-over)
Output switching voltage relay	≤ 30 VDC / ≤ 250 VAC
Switching current per output	≤ 2 A
Switching capacity per output	≤ 500 VA/60 W
Switching frequency	≤ 15 Hz
Contact quality	AgNi
Power-Bridge common alarm output	MOSFET, U _{max} = 30 V, I _{max} = 100 mA
Response characteristic	
Reference temperature	23 °C
Measuring accuracy current output (including linearity, hysteresis and repeatability)	± 10 μA
Temperature drift	≤ 0.0025 % of full scale/K
Galvanic isolation	
Test voltage	2.5 kV RMS
E1,E2-E3	375 V peak value acc. to EN 60079-11
E1,E2 supply voltage	375 V peak value acc. to EN 60079-11
E1,E2 collective fault indicator	375 V peak value acc. to EN 60079-11
A1A supply voltage	300 V RMS acc. to EN 50178 and EN 61010-1
E3 supply voltage	375 V peak value acc. to EN 60079-11
A1A-A1D	300 V RMS acc. to EN 50178 and EN 61010-1
A1A-E3	300 V RMS acc. to EN 50178 and EN 61010-1

Important note	For Ex-applications the values specified in the corresponding Ex certificates (ATEX, IECEx, UL, etc.) apply.
Important note	If the device is used in applications to achieve functional safety according to IEC 61508, the safety manual must be used. Information in the data sheet are not valid for functional safety.
Use in SIL safety circuits	SIL 2 acc. to IEC 61508
Displays/Operating elements	
Operational readiness	Green
Switching state	Yellow
Error indication	red

Mechanical data			
Protection class	IP20		
Flammability class acc. to UL 94	V-0		
Ambient temperature	-25...+70 °C		
Storage temperature	-40...+80 °C		
Dimensions	120 x 12.5 x 128 mm		
Weight	181 g		
Mounting instructions	DIN rail (NS35)		
Housing material	Polycarbonate/ABS		
Electrical connection	Removable spring-type terminals, 2-pin		
Connection variant	Power bridge with collective fault signal		
Terminal cross-section	0.2...2.5 mm ² (AWG: 24...14)		
Environmental conditions	Operating height	Up to 2000 m above sea level	
	Pollution degree	II	
	Surge/Overvoltage category	II (EN 61010-1)	
	Standards used		
	Voltage resistance and insulation		EN 50178
			EN 61010-1
			EN 50155
			GL VI-7-2
	Shock		EN 61373 class B
			EN 50155
			GL VI-7-2
			EN 60068-2-6
			EN 60068-2-27
	Temperature		EN 60068-2-1 Ad
			EN 50155
			GL VI-7-2
			EN 60068-2-2 Bd
			EN 60068-2-1
	Air humidity		EN 60068-2-38
	EMC		EN 50155
			GL VI-7-2
			NE21
			EN 61326-1
			EN 61326-3-1
			EN 61000-4-2
			EN 61000-4-3
			EN 61000-4-4
			EN 61000-4-5
		EN 61000-4-6	
		EN 61000-4-11	
		EN 61000-4-29	
		EN 55011	
		EN 55016	
		EN 50121-3-2	
	EN 61000-6-2		

Accessories

Type code	Ident no.		Dimension drawing
USB-2-IOL-0002	6825482	IO-Link Master with integrated USB port	
IOL-COM/3M	7525110	IO-Link communication line for connecting IO-Link devices to an IO-link master via a 3.5-mm jack plug	
IMX12-PS02-UI-UIR-PR/24VDC/CC	7580611	Power supply module power bridge; Collective fault signal via relay; Single and redundant power supply via terminals; Removable screw terminals	
IMC 1.5/ 5-ST-3.81 BK	7580954	Power Bridge Connection Terminal	
MCVR 1.5/ 5-ST-3.81 BK	7580955	Power Bridge Connection Terminal	
MC 1.5/ 5-ST-3.81 BK	7580956	Power Bridge Connection Terminal	

Accessories

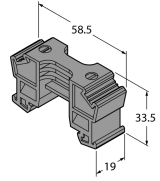
Type code	Ident no.		Dimension drawing
E/ME TBUS NS35 BK	7580957	Power Bridge Connection Terminal	
IMX12-SC-2X-4BK	7580940	Screw terminals for IM(X)12 modules; included in delivery: 4 pcs. of 2-pin black terminals	
IMX12-CC-2X-4BK	7580942	Spring terminals for IM(X)12 modules; included in delivery: 4 pcs. black terminals, 2-pin	