

STBVR81 W/30'

Photoelectric Sensor – Touch Switch For Two-Hand Control System

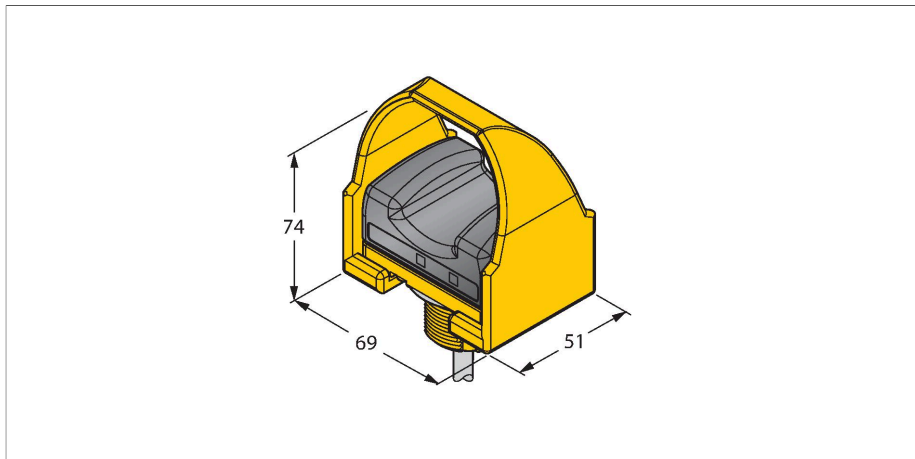

Technical data

Type	STBVR81 W/30'
ID no.	3066546
Optical data	
Function	Touch Button
Light type	IR
Electrical data	
Operating voltage	20...30 VDC
Operating voltage	20...30 VAC
Output function	Complementary contact, Relay output
Switching frequency	≤ 25 Hz
Mechanical data	
Design	Rectangular, STB
Dimensions	51 x 69 x 74 mm
Housing material	Plastic, PBT
Electrical connection	Cable, 9 m, PVC
Core cross-section	0.5 mm ²
Ambient temperature	0...+50 °C
Protection class	IP66
Power-on indication	LED, Green
Switching state	LED, Green
Error indication	LED, green, Flashing
Tests/approvals	

Features

- Cable, PVC, 9 m
- Protection class IP66
- Ergonomically shaped
- Upper housing part of polyetherimide
- Operating voltage: 20...30 V AC/DC
- Relay output, 125 VDC / 150 VAC, 1A DC / AC 0.4 A max.
- Pre-assembled protective cover
- Safety category 4 according to EN ISO 13849-1 for use with corresponding evaluation relays
- SIL 3 acc. to IEC 61508 and IEC 62061

Functional principle

The Duo-Touch two-hand control system can be used as a triggering device for most motor driven machines whose machining cycle is controlled by an operator. If a two-hand control system is used as a protective device, both of the operators hands must be used to start the machine cycle. The operator is thus placed in a form of "protective custody" if a hazard exists from which the operator must be protected or must avoid. The control elements of the two-hand control system must be arranged so that the hazardous motion (e.g. closing of a punching press) is completed or stopped before the operator can release one or both keys and reach the hazard area. Both hands must be used simultaneously. Both keys must be pressed within a time of max. 500 ms (simultaneity requirement according to EN 574).