

REM-103S10C-5C13S12M-H1181

Absolute Rotary Encoder - Multiturn

Industrial Line

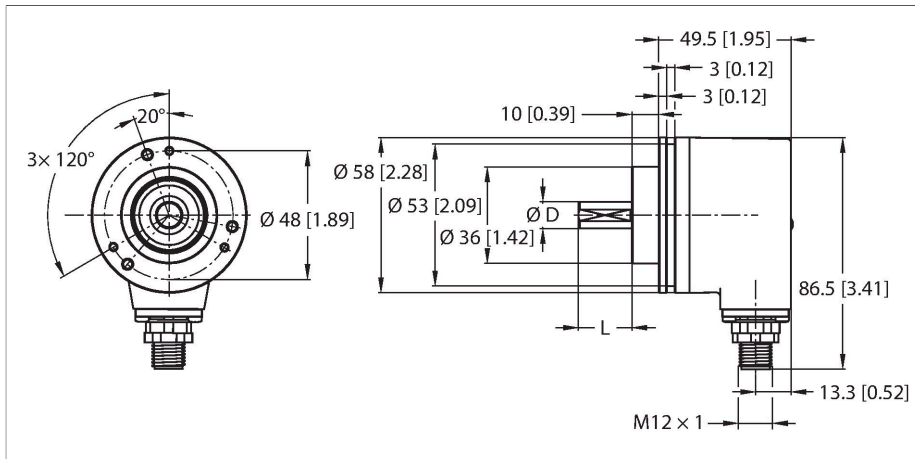

Technical data

Type	REM-103S10C-5C13S12M-H1181
ID	100011384
Measuring principle	Optical
General data	
Max. Rotational Speed	8000 rpm
Moment of inertia of the rotor	$3 \times 10^{-6} \text{ kgm}^2$
Starting torque	< 0.05 Nm
Absolute accuracy	$\pm 0.015^\circ$ At 25 °C
Output type	Absolute multiturn
Resolution singleturn	13 Bit
Resolution multiturn	12 Bit
Electrical data	
Operating voltage	10...30 VDC
No-load current	30 mA
Short-circuit protection	yes
Wire breakage/Reverse polarity protection	yes
Communication protocol	SSi
Output function	Binary coded
Mechanical data	
Design	Solid shaft
Flange type	Clamping flange
Flange diameter	Ø 58 mm
Shaft Type	Solid shaft
Shaft diameter D [mm]	10
Shaft Length L [mm]	20

Features

- Clamping flange, Ø 58 mm
- Solid shaft, Ø 10 mm × 20 mm
- Optical measuring principle
- Shaft material: stainless steel
- Protection class IP67 on housing and shaft side
- -40...+85 °C
- Max. 8000 rpm (continuous operation 5000 rpm)
- 10...30 VDC
- SSI, binary
- M12 × 1 male, 8-pin
- Singleturn, 13-bit resolution
- Multiturn, 12-bit resolution

Wiring diagram

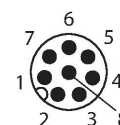
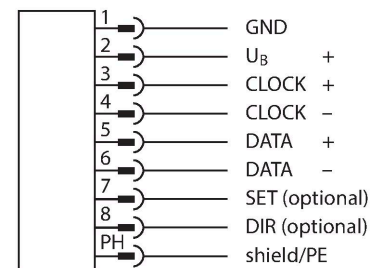

Technical data

Shaft material	Stainless steel
Housing material	Die-cast zinc
Electrical connection	Connector, M12 × 1
	8-polig
Axial shaft load	40 N
Radial shaft load	80 N
Environmental conditions	
Ambient temperature	-40...+85 °C
Vibration resistance (EN 60068-2-6)	100 m/s ² , 10...2000 Hz
Shock resistance (EN 60068-2-27)	2500 m/s ² , 6 ms
Protection class	IP67
Protection class shaft	IP67

Accessories

RCS-19-12-10	1545355	RCS-19-10-10	1545356
Bellows coupling, outer diameter: 19 mm, bore diameter: 12 mm/10 mm		Bellows coupling, outer diameter: 19 mm, bore diameter: 10 mm/10 mm	

Accessories

Dimension drawing	Type	ID	
	E-RKC 8T-264-2	U-04781	Connection cable, female M12, straight, 8-pin (twisted pairs), shielded, cable length: 2 m, sheath material: PVC, black; cULus approval; other cable lengths and qualities available, see www.turck.com

Accessories

Dimension drawing	Type	ID	
	RA-SAB-15-36	100038251	Spring arm for encoders with a 58-mm flange; recommended contact pressure 15 N; maximum contact pressure 30 N

Dimension drawing

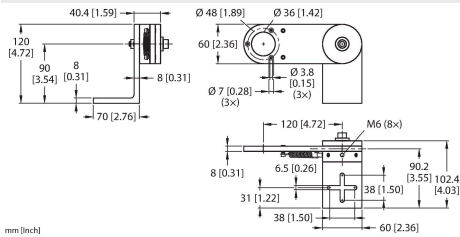

Type
RA-SAB-30-36

ID
100038294

Spring arm for encoders with a 58-mm flange; recommended contact pressure 30 N; maximum contact pressure 40 N

mm [inch]

RA-MW-200-12-DK1-10

100038302

Aluminum measuring wheel (cross knurled) for encoders; circumference 0.2 m, width 12 mm, D = 10 mm

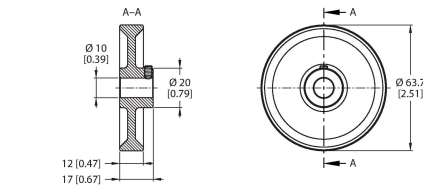

mm [inch]

RA-MW-200-12-PS1-10

100038303

Aluminum measuring wheel (smooth PU) for encoders; circumference 0.2 m, width 12 mm, D = 10 mm

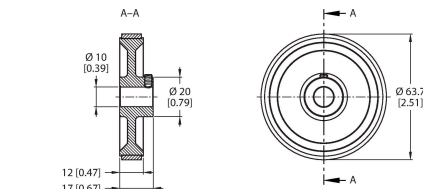

mm [inch]

RA-MW-200-12-RT1-10

100038304

Aluminum measuring wheel (studded PU) for encoders; circumference 0.2 m, width 12 mm, D = 10 mm

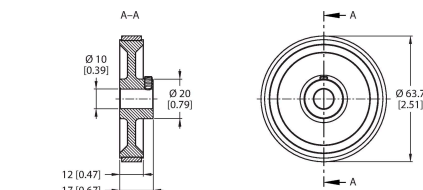

mm [inch]

RA-MW-200-12-PC1-10

100038305

Aluminum measuring wheel (grooved PU) for encoders; circumference 0.2 m, width 12 mm, D = 10 mm

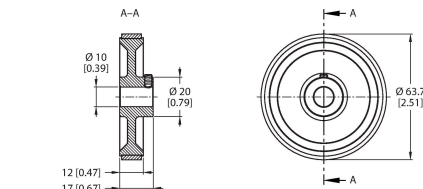

mm [inch]

RA-MW-300-12-DK1-10

100038306

Aluminum measuring wheel (cross knurled) for encoders; circumference 0.3 m, width 12 mm, D = 10 mm

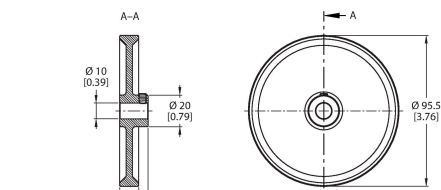

mm [inch]

RA-MW-300-12-PS1-10

100038307

Aluminum measuring wheel (smooth PU) for encoders; circumference 0.3 m, width 12 mm, D = 10 mm

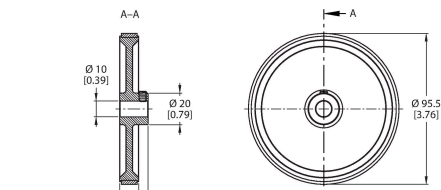

mm [inch]

Dimension drawing	Type	ID	
	RA-MW-300-12-RT1-10	100038308	Aluminum measuring wheel (studded PU) for encoders; circumference 0.3 m, width 12 mm, D = 10 mm
	RA-MW-300-12-PC1-10	100038309	Aluminum measuring wheel (grooved PU) for encoders; circumference 0.3 m, width 12 mm, D = 10 mm
	RA-MW-500-25-DK1-10	100038314	Aluminum measuring wheel (cross knurled) for encoders; circumference 0.5 m, width 25 mm, D = 10 mm
	RA-MW-500-25-PS1-10	100038315	Aluminum measuring wheel (smooth PU) for encoders; circumference 0.5 m, width 25 mm, D = 10 mm
	RA-MW-500-25-RT1-10	100038316	Aluminum measuring wheel (studded PU) for encoders; circumference 0.5 m, width 25 mm, D = 10 mm
	RA-MW-500-25-PC1-10	100038317	Aluminum measuring wheel (grooved PU) for encoders; circumference 0.5 m, width 25 mm, D = 10 mm