

TW860-960-L73-17-F-B42-15KPCS

UHF Tag

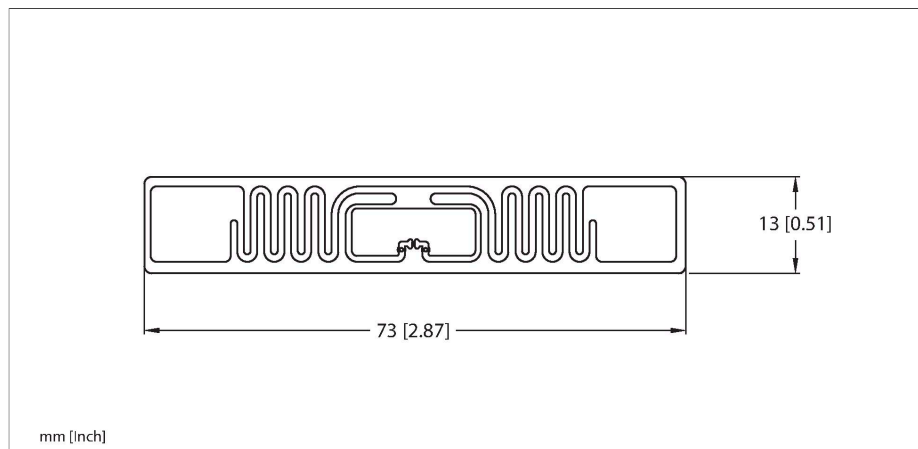

Features

- EEPROM, memory 42 byte
- TID serial number: 6 byte
- Not for direct mounting on metal

Functional principle

The UHF read/write heads form an air interface the size of which may vary, depending on the combination of read/write head and tag.

The read/write distances mentioned here only represent standard values measured under laboratory conditions and free from any influences caused by materials. Attainable distances may vary due to component tolerances, mounting conditions, ambient conditions and material qualities, especially when mounted in metal. Testing of the application under real operating conditions is therefore essential, especially with read/write on-the-fly!

Technical data

Type	TW860-960-L73-17-F-B42-15KPCS
ID	7030718
Remark to product	Smart-Label, self-adhesive, 15,000 pcs. on a roll
Data transfer	Alternating electromagnetic field
Technology	UHF RFID
Region (UHF)	Global (860...960 MHz) ETSI (865...868 MHz) FCC (902...928 MHz)
Reading range	8 m (2W ERP)
Memory type	EEPROM
Chip	Impinj Monza R6
Memory	42 Byte
Memory	Read/Write
Freely usable memory	0 Byte
EPC memory	12 byte
Number of read operations	unlimited
Number of write operations	10 ⁵
Typical read time	2 ms/Byte
Typical write time	3 ms/Byte
Radio communication and protocol standards	ISO 18000-63 EPCglobal Gen 2
Temperature during read/write access	-40...+85 °C
Temperature outside detection range	-40...+85 °C
Design	Smart Label
Housing length	73 mm
Housing width	17 mm
Protection class	IP40

Technical data

Packaging unit

1

Mounting instructions/Description

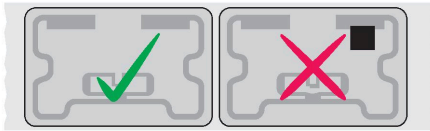

General Information

When mounting the tags, only remove them from the roll immediately before affixing them. Remove any dirt from the surfaces to be bonded and allow to dry. Liquids, oils, greases and other substances can reduce the effectiveness of the adhesive. If possible, affix the tag at room temperature (20–25 °C).

Defective tags are indicated by a black dot. Please do not use this tag.

Upon delivery, the number of marked defective tags is added to the total number of Smart Labels delivered.