

# piconet Extension Module for IP-Link

## 4 Analog Inputs 0(4)... 20 mA

### SNNE-40A-5007

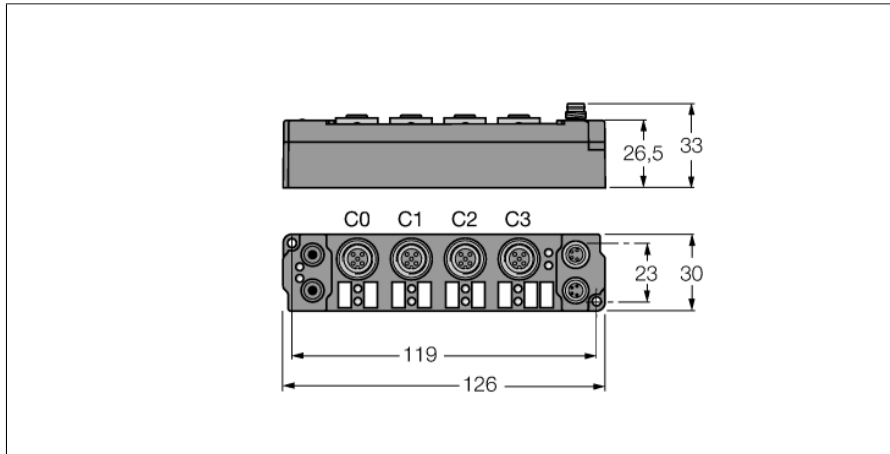

- 4 analog inputs 0(4)...20 mA
- Direct connection to the IP link
- Fibre-glass reinforced housing
- Encapsulated module electronics
- Metal connector
- Degree of protection IP67

#### M12 × 1 Input

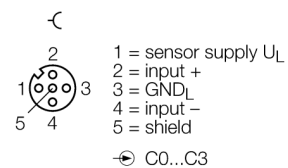

#### Connection - Inputs

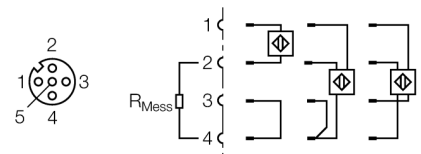

#### M8 × 1 Power Supply

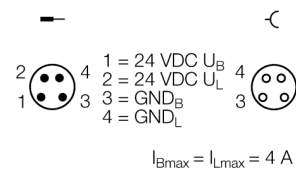

Type	SNNE-40A-5007
ID	6824514
Number of channels	4
Operating / load voltage	20...29 VDC
Operating current	≤ 55 mA
Fibre-optic length	≤ 15 m
Number of channels	4 analogue inputs 20 mA
Input resistance	80 Ω
Electrical isolation	channels to operational voltage
Common mode voltage	max. 35 V
Measuring current	0.5 mA
Conversion time	250 ms
Relative measuring error	< +- 0.3 % of full scale
Input filter	variable
Sensor supply	from load voltage
Dimensions (W x L x H)	30 x 126 x 26.5 mm
Vibration test	Acc. to EN 60068-2-6
Shock test	acc. to DIN EN 60068-2-27
Electromagnetic compatibility	Acc. to EN 61000-6-2/EN 61000-6-4
Protection class	IP67
Approvals	CE, cULus

## LEDs

	LED designation	Status green	Status red	Function
IP-Link / module status	RUN / ERR (I/O)	flickers/ON	OFF	Receiving error-free IP-Link protocols
		flickers	flickers	Receiving faulty IP-Link protocols
		OFF	flickers	Receiving faulty IP-Link protocols / system fault
		OFF	ON	No receipt of IP-Link protocols / module error
Inputs	R / E (1...4)	OFF		No data transmission
		ON		Data transmission to D/A converter
			OFF	Error-free data transmission
			ON	Wire break, measured value out of measuring range, etc.
Power supply	U <sub>B</sub>	OFF		Operating voltage U <sub>B</sub> < 18 VDC
		ON		Operating voltage U <sub>B</sub> ≥ 18 VDC
	U <sub>L</sub>	OFF		Load voltage U <sub>L</sub> < 18 VDC
		ON		Load voltage U <sub>L</sub> ≥ 18 VDC

## Data in process image

	Address	Input data		Output data		
		Word	High-Byte	Low-Byte	High-Byte	Low-Byte
Valid for the setting "Motorola format"  SBn: Status byte channel n CBn: Control byte channel n Chn D0: channel n, least significant data byte Chn D1: channel n, most significant data byte	<b>Pre-conditions</b>					
	<b>Compact mapping:</b> Starting with Ch0 D1 in "Low-Byte" word 0 all other bytes follow immediately. Only the user data are mapped (greyed in the table).	<b>0</b>	Ch0 D1	SB0	Ch0 D1	CB0
		<b>1</b>	SB1	Ch0 D0	CB1	Ch0 D0
		<b>2</b>	Ch1 D0	Ch1 D1	Ch1 D0	Ch1 D1
		<b>3</b>	Ch2 D1	SB2	Ch2 D1	CB2
		<b>4</b>	SB3	Ch2 D0	CB3	Ch2 D0
	<b>5</b>	Ch3 D0	Ch3 D1	Ch3 D0	Ch3 D1	