

Q45AD9F

Photoelectric Sensor – Photoelectric Sensor for Glass Fibers

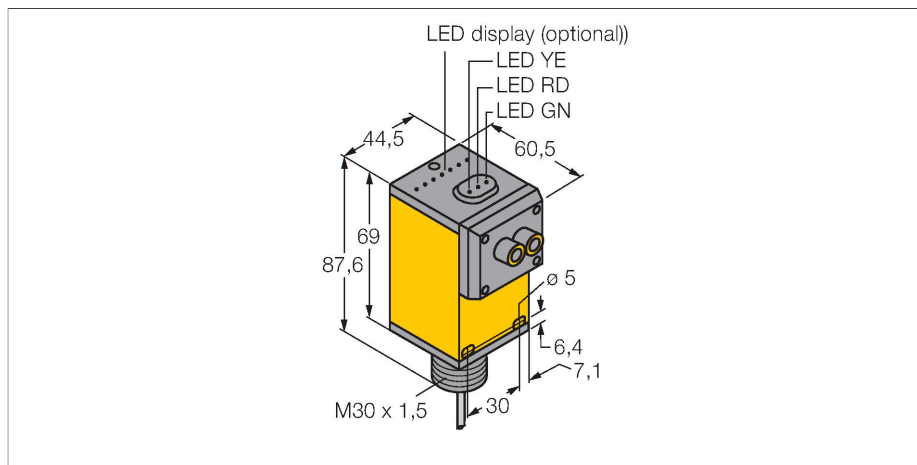

Features

- Cable, PVC, 2 m
- Protection class IP67
- Sensitivity adjusted via potentiometer
- Operating voltage: 5...15 VDC
- NAMUR output: dark \leq 1.2 mA ; light \geq 2.1 mA
- Acc. to EN 60947-5-6 (NAMUR)
- ATEX category II 1 G, Ex zone 0

Wiring diagram

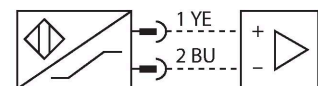

Technical data

Type	Q45AD9F
ID no.	3037621
Optical data	
Function	Photoelectric sensor for glass fibers
Fiber-optic type	glass
Light type	IR
Wavelength	880 nm
Electrical data	
Voltage	Nom. 8.2 VDC
Current consumption non-actuated	\leq 1 mA
Actuated current consumption	\geq 2.1 mA
No-load current	\leq 2.1 mA
Output function	Light operation, NAMUR
Switching frequency	\leq 100 Hz
Response time typical	$<$ 5 ms
Setting option	Potentiometer
Mechanical data	
Design	Rectangular, Q45
Dimensions	60.5 x 44.5 x 87.6 mm
Housing material	Plastic, Thermoplastic material
Lens	plastic, Acrylic
Electrical connection	Cable, 2 m, PVC
Number of cores	2
Core cross-section	0.5 mm ²
Ambient temperature	-40...+70 °C
Relative humidity	0...90 %
Protection class	IP67

Functional principle

Glass or fibre optic sensors are the optimum choice for high temperature or space restricted applications. Fibre optics transfer the light from the sensor to a remote object. Individual fibre optics are used for opposed mode sensing, whereas bifurcated fibre optics are suited for retro-reflective or diffuse mode operation.

Excess gain curve
Excess gain in relation to the distance

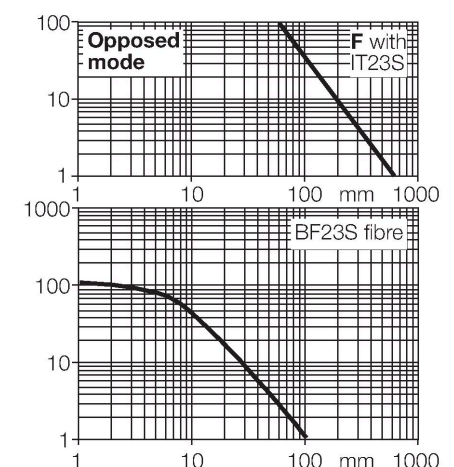

Technical data

Special features	Wash down
Switching state	LED, Red
Excess gain indication	LED, flashing
Tests/approvals	
MTTF	67 years acc. to SN 29500 (Ed. 99) 40 °C
Approvals	CE, FM, CSA
Approvals	ATEX II 1G ATEX II 2G ATEX II 3G
Device marking	Ⓔ II 1 G Ex ia IIC T5 Ga
Ignition protection category	Ex ia IIC T5 Ga
Ex approval acc. to conformity certificate	FM12ATEX0094X

Accessories

SMB30A

3032723

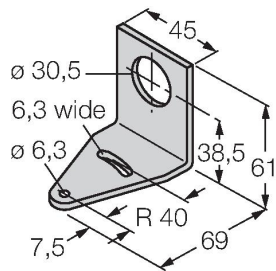

Mounting bracket, rectangular, stainless steel, for sensors with 30mm thread

SMB30FAM10

3011185

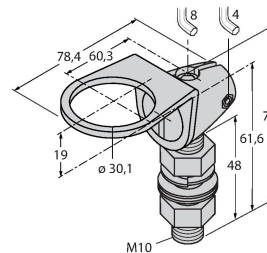

Mounting bracket, stainless steel, for M10 x 1.5 thread, thread length 30 mm

SMB30SC

3052521

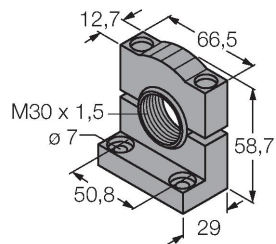

Mounting bracket, PBT black, for sensors with 30 mm thread, rotatable

Accessories

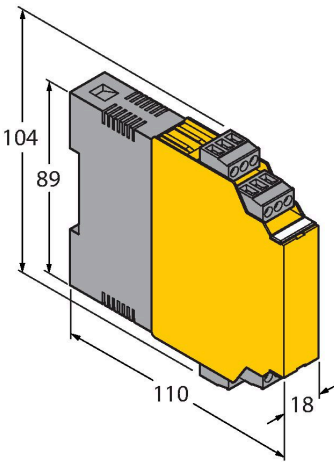
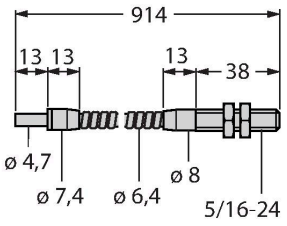
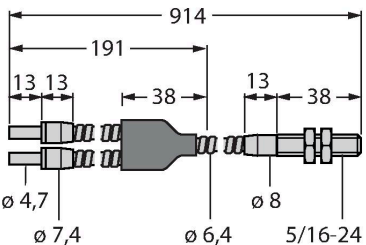
Dimension drawing	Type	ID no.	
 <p>Technical drawing of the IM1-22EX-R isolating switching amplifier. The drawing shows a perspective view of the device with dimensions: total height 104 mm, mounting height 89 mm, total width 110 mm, and front panel width 18 mm.</p>	IM1-22EX-R	7541231	Isolating switching amplifier, 2-channel; 2 relay outputs; input NAMUR signal; selectable ON/OFF mode for wire-break and short-circuit monitoring; adjustable output mode (NO / NC mode); removable terminal blocks; width 18 mm; universal power supply unit
 <p>Technical drawing of the IT23S glass fiber sensor. The drawing shows a side view with dimensions: total length 914 mm, two 13 mm sections at the input, a 13 mm section at the output, and a 38 mm section at the output. Diameters are specified as $\varnothing 4,7$, $\varnothing 7,4$, $\varnothing 6,4$, and $\varnothing 8$. The output is labeled 5/16-24.</p>	IT23S	3017355	Glass fiber, sensing mode: Opposed mode, threaded sleeve (brass), bundle diameter 3.2 mm, flexible stainless steel jacket, ambient temperatures -140...+250 °C
 <p>Technical drawing of the BT23S glass fiber sensor. The drawing shows a side view with dimensions: total length 914 mm, a 191 mm section at the input, two 13 mm sections at the input, a 38 mm section at the input, a 13 mm section at the output, and a 38 mm section at the output. Diameters are specified as $\varnothing 4,7$, $\varnothing 7,4$, $\varnothing 6,4$, and $\varnothing 8$. The output is labeled 5/16-24.</p>	BT23S	3017276	Glass fiber, sensing mode: Diffuse mode, threaded sleeve (brass), bundle diameter 3.2 mm, flexible stainless steel jacket, ambient temperatures -140...+250 °C

Operating Instructions

Intended use	This device fulfills the directive 94/9/EC and is suited for use in explosion hazardous areas according to EN60079-0:2009, -11:2012, -26:2007. In order to ensure correct operation to the intended purpose it is required to observe the national regulations and directives.
For use in explosion hazardous areas conform to classification	II 1 G (Group II, Category 1 G, electrical equipment for gaseous atmospheres).
Marking (see device or technical data sheet)	Ⓔ II 1 G and Ex ia IIC T5 Ga acc. to EN60079-0, -11 and -26
Local admissible ambient temperature	-25...+70 °C
Installation/Commissioning	<p>These devices may only be installed, connected and operated by trained and qualified staff. Qualified staff must have knowledge of protection classes, directives and regulations concerning electrical equipment designed for use in explosion hazardous areas. Please verify that the classification and the marking on the device comply with the actual application conditions.</p> <p>This device is only suited for connection to approved Exi circuits according to EN 60079-0 and EN 60079-11. Please observe the maximum admissible electrical values. After connection to other circuits the sensor may no longer be used in Exi installations. When interconnected to (associated) electrical equipment, it is required to perform the "Proof of intrinsic safety" (EN60079-14).</p>
Installation and mounting instructions	Avoid static charging of cables and plastic devices. Please only clean the device with a damp cloth. Do not install the device in a dust flow and avoid build-up of dust deposits on the device. If the devices and the cable could be subject to mechanical damage, they must be protected accordingly. They must also be shielded against strong electro-magnetic fields. The pin configuration and the electrical specifications can be taken from the device marking or the technical data sheet. In order to avoid contamination of the device, please remove possible blanking plugs of the cable glands or connectors only shortly before inserting the cable or opening the cable socket.
Service/Maintenance	Repairs are not possible. The approval expires if the device is repaired or modified by a person other than the manufacturer. The most important data from the approval are listed.