

CABLE5X0.34-XX-PUR-YE-500M/TXY3713

Actuator and Sensor Cable, PUR – Bulk Cable

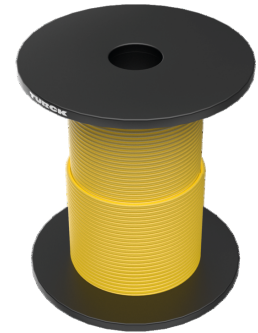
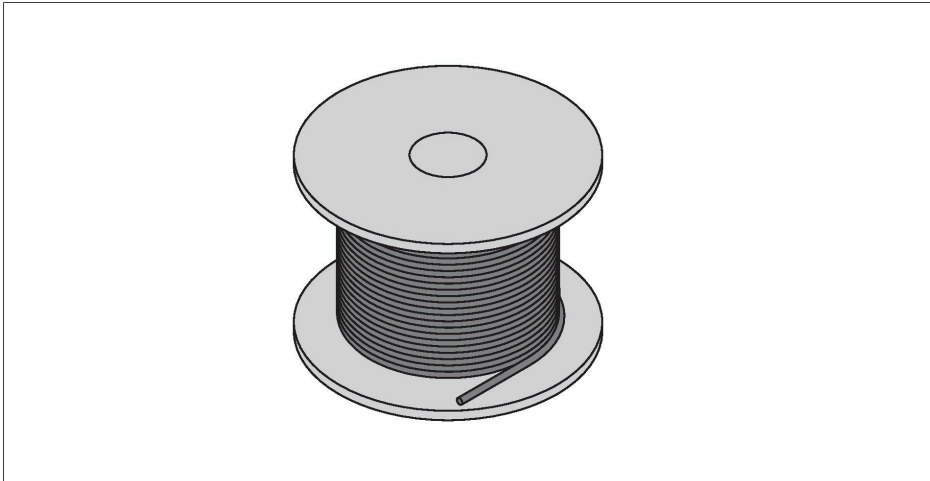

Technical data

Type	CABLE5X0.34-XX-PUR-YE-500M/TXY3713
ID	6635757
Remark to product	Specification according to VASS requirements (version: February 2021)
Cable	
Cable diameter	Ø 6 mm ±0.20
Cable length	500 m
Cable jacket	PUR, Yellow
Core insulation	PP
Core cross-section	5 x 0.34 mm ²
Arrangement of strands	42 x 0.1 mm
Core colors	BN, WH, BU, BK, GY
Electrical properties at +20 °C	
Rated voltage	300 V
Test voltage	2000 V
Current	4 A
Insulation resistance	> 30.5 MΩ/km
forward resistance	max. 57 Ω/km
Mechanical and chemical properties	
Bending radius (stationary installation)	≥ 5 x Ø
Bending radius (flexible use)	≥ 10 x Ø
Bending cycles	≥ 5 million
Admissible acceleration	max. 5 m/s ²
Admissible travel path, horizontal	5 m (at 5 m/s ²)
Admissible travel path, vertical	2 m (at 5 m/s ²)
Admissible traversing speed	3.3 m/s

Features



- Jacket material: PUR
- Jacket color: Yellow
- Resistant to welding sparks
- Suitable for drag chain use
- Resistant to chemicals, UV radiation and oils
- Flame retardant (acc. to FT2 (UL/CSA); IEC 60332-1-2; IEC 60332-2-2)
- Halogen free (acc. to EN 50267)
- Free from silicone, PVC and LABS
- Particularly resistant to abrasion
- RoHS compliant
- Cable length: 500 m

Technical data

Torsional stress	± 180 °/m
Ambient temperature range (stationary)	-50...+80 °C
Ambient temperature range (In motion)	-25...+80 °C
Ambient temperature during drag chain operation	-25...+60 °C

Accessories

TORQUE-WRENCH-SET-AS	6936170
----------------------	---------

Torque wrench set; handles with adjustable torque 0.4-1.0 Nm, torque wrench for M8 (SW9), fork wrench for M12 (SW 14)

Accessories

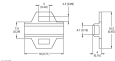
Dimension drawing	Type	ID	
	LABEL-HOLDER-FLEX-PVC	100048170	PVC label holder for identification of extension cables (TEL/TXL product series); for cable diameters: min. 5 mm; dimensions 4 × 18 mm; delivery unit: 50 pcs. per package