

SC26-2D

Safety Technology – Programmable Safety Controller

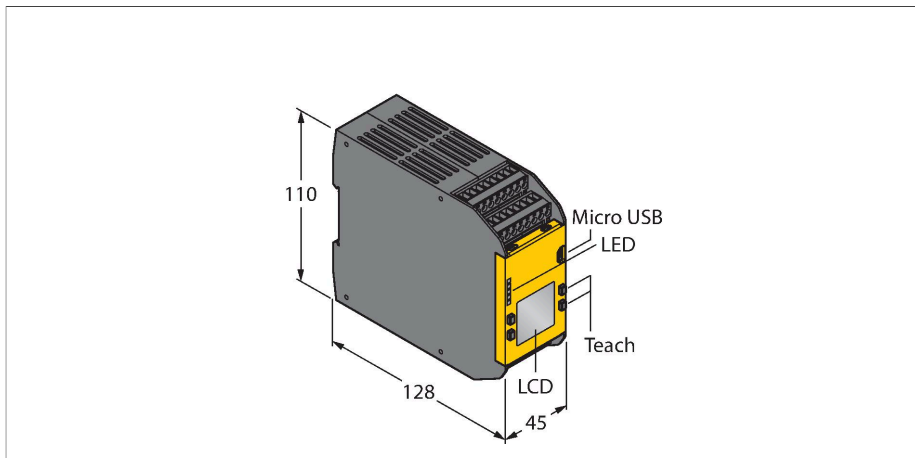

Technical data

Type	SC26-2D
ID no.	3085066
Function	Controller
Operating voltage	20...28 VDC
No-load current	≤ 120 mA
Number of safe semiconductor outputs	2
Response time typical	< 10 ms
Design	Rectangular, SC26
Dimensions	128 x 45 x 110 mm
Housing material	Plastic, Black
Electrical connection	Removable terminal block, reverse polarity protected, screw connection
Ambient temperature	0...+55 °C
Relative humidity	0...90 %
Protection class	IP20
Power-on indication	LED, Green
Switching state	LED, Red/Green
Tests/approvals	
Approvals	CE, cULus listed

Features

- PLe acc. to ISO 13849-1
- Safety category 4 acc.to EN 954-1
- SIL 3 acc. to IEC 61508 and IEC 62061
- Settings made via pushbutton or software
- 26 inputs, of which 8 can be reconfigured as outputs
- 2 independent safety outputs
- Intuitive programming interface
- Display
- Operating voltage 24 VDC +20%
- Protection class IP20
- Freeware (included in delivery)

Wiring diagram

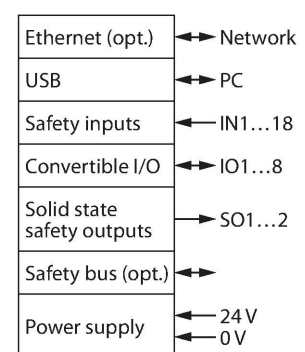

Functional principle

The safety controller can have multiple safety relay modules for the use of emergency stop switches, door-lock switches, safety light screens, two-hand controls, safety mats and other protective devices.

The safety controller can be configured with the software and automatically generates a wiring diagram and a ladder diagram logic. For the transfer of software created configuration you can either connect a serial

USB-cable or an XM-memory card to the the Micro USB port of the controller. You can display many different events such as the system status, failure diagnosis and configuration overview via the pushbuttons and the LCD panel and also read and write the configuration file via XM memory card.

Accessories

Dimension drawing	Type	ID no.	
Kein Maßbild vorhanden/ No dimension drawing available	SC-TC2	3085078	Terminal block with cage clamps; 8 ports
Kein Maßbild vorhanden/ No dimension drawing available	SC-TS2	3085076	Terminal block with cage clamps; 8 ports
Kein Maßbild vorhanden/ No dimension drawing available	SC-XMP2	3029482	Programming adapter

Accessories

Dimension drawing	Type	ID no.	
	SC-USB2	3029480	Serial USB cable, type A to Micro-B; length: 1.8m

**Kein Maßbild vorhanden/
No dimension drawing available**

	SC-XM2	3029481	External memory card, Micro-B; EEPROM configuration
--	--------	---------	---

**Kein Maßbild vorhanden/
No dimension drawing available**

	CD ROM XS26-2 SAFETY CONTROLLER CONFIGUR	3090443	CD-ROM, configuration software, operating instructions;
--	--	---------	---