

FOUNDATION fieldbus Backplane for the DPC System DPC-49-4RMB

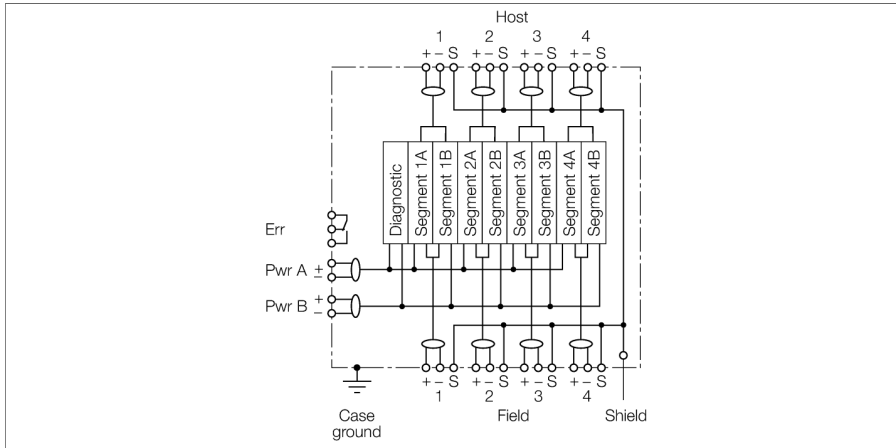

The DPC (Diagnostic Power Conditioner) system is a power supply system for installing FOUNDATION™ fieldbus H1 segments. The system provides extensive diagnostic options for monitoring FOUNDATION™ fieldbus segments and thus supports plant-wide asset management.

A DPC system consists of one or more module racks, each of which can take up to eight DPC-49-IPS1 power supply modules and one DPC-49-ADU or DPC-49-DU diagnostic module. Up to four H1 segments per module rack can be operated and monitored redundantly in the FOUNDATION™ fieldbus network. The diagnostic data of the H1 segments can be transmitted via the DPC-49-HSEFD/24VDC HSE field device to the higher level Asset Management System (only in conjunction with the diagnostic module DPC-49-ADU).

The module rack consist of a backplane and the actual rack system for the power supply modules and the diagnostics module.

The individual components of the system are electrically linked via the connection terminals of the backplane. From an electrical perspective, the backplane is to be considered to be passive.

The power can be supplied via two 2-pole screw connectors. The connection of the host system is established per segment via removable 3-pole screw terminals. For the connection of the H1 segments to the fieldbus side, each segment is individually connected with a removable 3-pole screw terminal.

NOTE: If H1 applications are to be set up redundantly at the DPC system, they must be connected to the field port as the host port is limited to 21 mA.

The shielding is achieved via insulated shield bus or via the 3-pole screw terminal, which is internally connected with the M5 threaded bolt for equipotential bonding. A further M5 threaded bolt for equipotential bonding is simply connected to the housing.

For simple diagnostics processing, a connection is provided to the relay alarm contact of the diagnostics module.

- Module rack for up to eight power supply modules and one diagnostic module for up to four redundant H1 segments.
- Redundant power supply
- Removable terminal blocks with screw connections
- RJ45 connector for HSE fieldbus diagnostics

Type	DPC-49-4RMB
ID	6882024
Operating voltage	18...32 VDC
Surge protection	> 250 VDC
Displays/Operating elements	
Electrical connection	Removable terminal block, reverse polarity protected, screw connection RJ45 socket
Protection class	IP20
MTTF	115 years acc. to SN 29500 (Ed. 99) 40 °C
Ambient temperature	-20...+60 °C
Housing material	Aluminium
Housing color	Black/yellow
Dimensions	220 x 210 x 113 mm
Connection mode	snap-fit on DIN rail (DIN 60715)

Dimensions

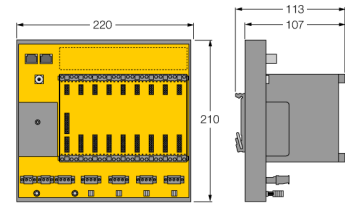

Accessories

Type code	Ident no.		Dimension drawing
BM-DPC	6882015	blind module for unused slots	