

FCIC-G1/4A4P-LIL-H1141/2.0

Flow Monitoring – Compact Inline Flow Sensors of the FCIC Series

Analog Output 4...20 mA Linearized for Water

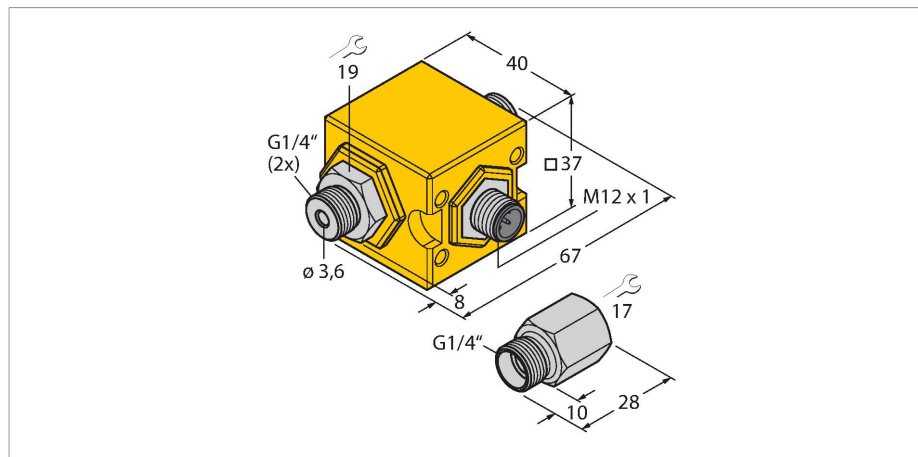

Features

- Thermodynamic operating principle
- flow monitoring of water
- Ready for use, no alignment
- Operating range 0.05...2.0 l/min
- Initial value 4 mA at 0 l/min
- End value 20 mA at 2 l/min
- Load resistance, 200 ... 500 Ohm
- Operating voltage side polarized
- Analog output 4...20 mA
- Linearized for water
- Compact design
- Incl. adapter

Technical data

ID	6870784
Type	FCIC-G1/4A4P-LIL-H1141/2.0
Mounting conditions	Inline sensor
Flow operating range	0.05...2 l/min
Stand-by time	typ. 10 s (2...15 s)
Switch-on time	typ. 1 s (0.5...10 s)
Medium temperature	0...+60 °C
Ambient temperature	0...+60 °C
Electrical data	
Operating voltage	21.6...26.4 VDC
Current consumption	≤ 70 mA
Output function	Analog output
Current output	4...20 mA
Protection class	IP67
Mechanical data	
Design	Inline
Housing material	Plastic, PBT-GF30
Sensor material	Stainless steel, 1.4571 (AISI 316Ti)
Electrical connection	Connector, M12 × 1
Pressure resistance	10 bar
Process connection	G 1/4"
Tests/approvals	
Approvals	cULus
UL registration number	E210608

Wiring diagram

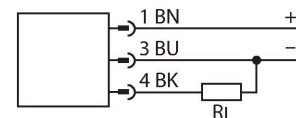

Functional principle

The FCIC inline flow sensors operate on the thermodynamic principle.

Depending on the version the sensors detect aqueous media from 0.05 to 2 l/min. In addition to the classic transistor switching output there is also a linear 4 ... 20 mA and a linear pulse output available with a clock rate of 1 ml/pulse.

The sensors are already pre-configured and must no longer be matched by the customer. They are therefore immediately ready for operation.

To ensure a linear signal over the entire coverage, the sensors must be operated with the supplied adapter. The sensors with analog and pulse output provide a linear signal proportional to the flow rate in the specified operating range. However, it must be noted that water additives can lead to linear deviation.

In addition, the stable and small-scale design makes the sensors resistant to moisture and vibration. It also simplifies the integration into already existing and new applications. Not least in hard-to-reach places the FCIC play to their strengths.

Mounting instructions

Mounting adapter	All sensors of the FCIC series are used with an adapter. This ensures a linear signal over the entire coverage. The adapter is screwed on to the process connection at the infeed side.
Mounting position	In order to minimize potential misinterpretations due to disturbance, it is recommended to position the sensor with a minimum separation distance of $3 \times d_i$ before and $5 \times d_i$ after bends, changes in cross section, valves, etc.. <ul style="list-style-type: none"> ■ If deposits are likely to built up, it is recommended to clean the sensor at regular intervals and to select the associated service interval accordingly. ■ If the sensor is mounted in vertical piping systems, it is recommended to position the sensor within the riser.

Accessories

Dimension drawing	Type	ID	
	RKC4.4T-P7X2-10/TXL	6626184	Connection cable, M12 female connector, straight, 4-pin, LED, cable length: 10 m, jacket material: PUR, black; cULus approval
	RKC4.4T-2/TXL	6625503	Connection cable, M12 female connector, straight, 4-pin, cable length: 2 m, jacket material: PUR, black; cULus approval
	WKC4.4T-2/TXL	6625515	Connection cable, M12 female connector, angled, 4-pin, cable length: 2 m, jacket material: PUR, black; cULus approval