

TW865-868-Q30L115-M-B112

UHF Tag

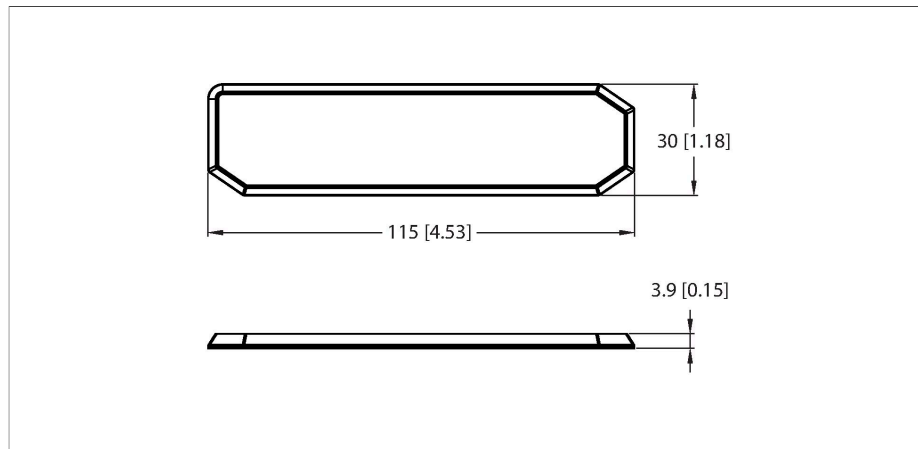

Features

- 168-h exposure of engine oil
- 168-h exposure of salt water (salt content 10 %)
- 168-h exposure of sulfuric acid (10 %, pH 2)
- 1-h exposure of NaOH (10 %, pH 13)
- EEPROM, memory 112 byte
- TID memory: 12 byte
- For direct mounting on metal

Functional principle

The UHF read/write heads form an air interface the size of which may vary, depending on the combination of read/write head and tag.

The read/write distances mentioned here only represent standard values measured under laboratory conditions and free from any influences caused by materials.

Attainable distances may vary due to component tolerances, mounting conditions, ambient conditions and material qualities, especially when mounted in metal.

Testing of the application under real operating conditions is therefore essential, especially with read/write on-the-fly!

Technical data

Type	TW865-868-Q30L115-M-B112
ID	100003971
Remark to product	For direct mounting on metal
Data transfer	Alternating electromagnetic field
Technology	UHF RFID
Region (UHF)	ETSI (865...868 MHz)
Reading range on metal	9 m (2W ERP)
Memory type	EEPROM
Chip	Impinj Monza 4QT
Memory	112 Byte
Memory	Read/Write
Freely usable memory	64 Byte
EPC memory	16 byte
Number of read operations	unlimited
Number of write operations	10 ⁵
Typical read time	2 ms/Byte
Typical write time	3 ms/Byte
Radio communication and protocol standards	ISO 18000-63 EPCglobal Gen 2
Temperature during read/write access	-35...+85 °C
Temperature outside detection range	-35...+85 °C
Design	Hard tag
Housing length	30 mm
Housing width	115 mm
Housing height	3.9 mm
Active area material	Plastic, grey
Protection class	IP68

Technical data

Packaging unit

1
