

K30APPBGREQP

Pick-to-Light – Placement Sensor

Pushbutton for Picking Processes

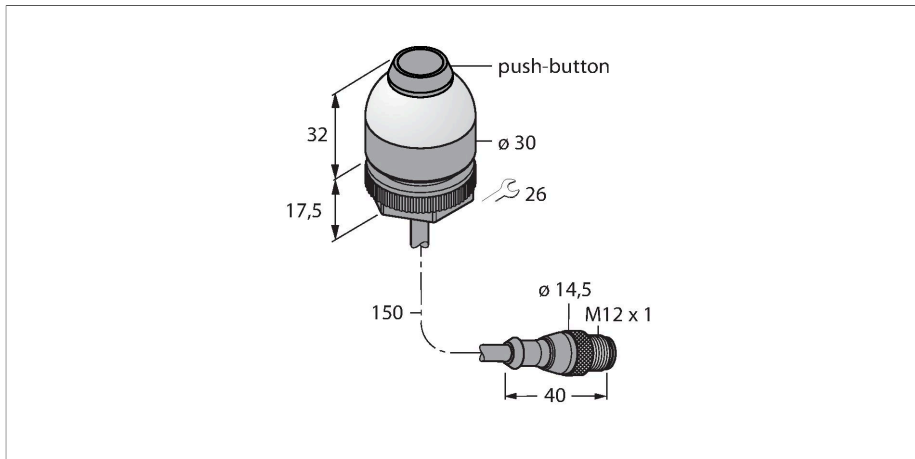

Features

- Operating voltage 12...30 VDC
- Protection class IP67
- 150 mm cable with male end M12 x 1, 4-pin
- Frontal pushbutton for acknowledgement
- Job light: green
- Mispick: red
- Actuation: not signalled
- Operating voltage 12...30 VDC
- PNP switching
- NO contact

Wiring diagram

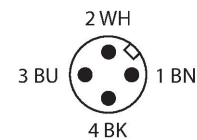
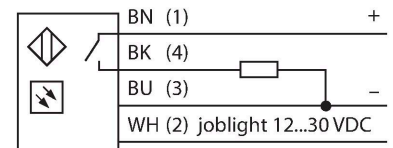

Technical data

Type	K30APPBGREQP
ID	3017603
Signal and display data	
Purpose	Pick-to-Light
Function	Pushbutton
Light type	Green Red
Switch Function	Momentary
Features of color 1	Green, Permanently on
Features of color 2	Red
Electrical data	
Operating voltage	12...30 VDC
DC rated operational current	≤ 150 mA
Max. current consumption per color	55 mA
Output function	NO contact, PNP
Input type	PNP
Response time typical	< 150 ms
Mechanical data	
Design	Dome, K30
Dimensions	Ø 30 x 49.4 mm
Housing material	Plastic, PC Thermoplastic material, Black
Window material	Polycarbonate, diffuse
Electrical connection	Cable with connector, M12 x 1, 0.15 m, PVC
Number of cores	4

Functional principle

The K30 pick-and-place sensor is suitable for many assembly and placement sequences. The green work light or other signal lights are reflected perfectly by the entire dome (depending on the version). The transistor output can be easily connected to a system control, which is programmed for a special task sequence. The work light of the sensor is located in or next to every bin at the operator's workstation and indicates: 1. The bins with the components to be picked up for a particular work step and 2. the sequence in which the components have to be picked up. If the operator removes a part from the bin, the K30 detects the hand in the bin and sends a signal to the control unit. The system then checks if the correct component has been picked up and – depending on the configuration – switches the corresponding work light off and the next one on, according to the assembly sequence. The work sequence control leads to increased efficiency, improved quality control and reduces rework and testing expenses. The term work light therefore refers to the visual indicator of the bin from which a part should be removed next. The actuation indicator confirms the removal with a different color. The mispick indicator illuminates if a bin

Technical data

was reached into when the work light was not set.

Ambient temperature	-40...+50 °C
Relative humidity	0...90 %
Protection class	IP65
Tests/approvals	
Approvals	CE

Accessories

SMB22A

3079414

Mounting bracket, stainless steel, for K30L series

