



EN Operating instructionspages 1 to 6
Original

Content

1 About this document

1.1 Function 1

1.2 Target group: authorised qualified personnel. 1

1.3 Explanation of the symbols used 1

1.4 Appropriate use 1

1.5 General safety instructions 1

1.6 Warning about misuse 2

1.7 Exclusion of liability 2

2 Product description

2.1 Ordering code 2

2.2 Special versions. 2

2.3 Determination and use for functional safety in accordance with the Machinery Directive. 2

2.4 Determination and use for explosion protection. 2

2.5 Technical data 2

2.6 Safety classification 2

3 Mounting

3.1 General mounting instructions 3

3.2 Dimensions 3

3.3 Accessories 3

3.4 Axial misalignment. 3

3.5 Adjustment. 3

4 Electrical connection

4.1 General information for electrical connection. 4

4.2 Contact Options 4

4.3 Connection. 4

5 Set-up and maintenance

5.1 Functional testing. 4

5.2 Maintenance 4

6 Disassembly and disposal

6.1 Disassembly. 4

6.2 Disposal 4

7 EU Declaration of conformity

1. About this document

1.1 Function

This operating instructions manual provides all the information you need for the mounting, set-up and commissioning to ensure the safe operation and disassembly of the safety switchgear. The operating instructions must be available in a legible condition and a complete version in the vicinity of the device.

1.2 Target group: authorised qualified personnel

All operations described in this operating instructions manual must be carried out by trained specialist personnel, authorised by the plant operator only.

Please make sure that you have read and understood these operating instructions and that you know all applicable legislations regarding occupational safety and accident prevention prior to installation and putting the component into operation.

The machine builder must carefully select the harmonised standards to be complied with as well as other technical specifications for the selection, mounting and integration of the components.

1.3 Explanation of the symbols used



Information, hint, note:

This symbol indicates useful additional information.



Caution: Failure to comply with this warning notice could lead to failures or malfunctions.

Warning: Failure to comply with this warning notice could lead to physical injury and/or damage to the machine.

1.4 Appropriate use

The Schmersal range of products is not intended for private consumers.

The products described in these operating instructions are developed to execute safety-related functions as part of an entire plant or machine. It is the responsibility of the manufacturer of a machine or plant to ensure the correct functionality of the entire machine or plant.

The safety switchgear must be exclusively used in accordance with the versions listed below or for the applications authorised by the manufacturer. Detailed information regarding the range of applications can be found in the chapter "Product description".

1.5 General safety instructions

The user must observe the safety instructions in this operating instructions manual, the country specific installation standards as well as all prevailing safety regulations and accident prevention rules.



Further technical information can be found in the Schmersal catalogues or in the online catalogue on the Internet: products.schmersal.com.

The information contained in this operating instructions manual is provided without liability and is subject to technical modifications.

There are no residual risks, provided that the safety instructions as well as the instructions regarding mounting, commissioning, operation and maintenance are observed.

1.6 Warning about misuse



In case of improper use or manipulation of the safety switchgear, personal hazards or damages to machinery or plant components cannot be excluded.

1.7 Exclusion of liability

We shall accept no liability for damages and malfunctions resulting from defective mounting or failure to comply with this operating instructions manual. The manufacturer shall accept no liability for damages resulting from the use of unauthorised spare parts or accessories.

For safety reasons, invasive work on the device as well as arbitrary repairs, conversions and modifications to the device are strictly forbidden, the manufacturer shall accept no liability for damages resulting from such invasive work, arbitrary repairs, conversions and/or modifications to the device.

2. Product description

2.1 Ordering code

This operating instructions manual applies to the following types:

EX-BNS 33-①Z②-3G/D

No.	Option	Description
①	11	1 NO contact / 1 NC contact without LED
②	G	with LED

EX-BNS 33-①Z②-2187-3G/D

No.	Option	Description
①	12	1 NO contact / 2 NC contacts
	02	2 NC contacts without LED
②	G	with LED

2.2 Special versions

For special versions, which are not listed in the ordering code below 2.1, these specifications apply accordingly, provided that they correspond to the standard version.

2.3 Determination and use for functional safety in accordance with the Machinery Directive.

The safety sensor can be used for monitoring the position of movable guards and flaps.

The safety sensors are used for applications, in which the hazardous situation is terminated without delay when the safety guard is opened.



The user must evaluate and design the safety chain in accordance with the relevant standards and the required safety level.



The safety switchgears are classified according to EN ISO 14119 as type 4 interlocking devices.



The entire concept of the control system, in which the safety component is integrated, must be validated to the relevant standards.

Only the entire system consisting of the safety sensor (EX-BNS), the actuator (EX-BPS) and the safety-monitoring module (e.g. SRB(-E) / PROTECT-SELECT / PSC1) meets the requirements of the standard EN 60947-5-3.

2.4 Determination and use for explosion protection

The components can be used in potentially explosive atmospheres of Zone 2 and 22 equipment category 3GD. The installation and maintenance requirements to the standard series 60079 must be met. For the actuation of the safety sensors, only the EX-BPS 33-3GD actuator can be used.

Explosion protection is achieved with ignition protection types Ex nC (hermetically sealed device) and Ex tc (protection through enclosure).

Conditions for safe operation

The specific ambient temperature range must be observed. The user must provide for a protection against the permanent influence of UV rays. The energy restriction for LED versions (24 V/10 mA) must be ensured by the user.

2.5 Technical data

Marking in accordance with the ATEX Directive: Ⓔ II 3G
Ⓔ II 3D

Marking in accordance with standards:

- EX-BNS 33: Ex nC IIC T6 Gc X;
Ex tc IIIC T80°C Dc X

- EX-BPS 33: Ex h IIC T6 Gc;
Ex h IIIC T80°C Dc

Applied standards: EN 60947-5-3,
EN IEC 60079-0, EN IEC 60079-15, EN 60079-31,
EN 13463-1, EN ISO 80079-36, EN ISO 80079-37

Design: rectangular

Enclosure: glass-fibre reinforced thermoplastic

Protective enclosure: Stainless steel

Max. impact energy: without protective enclosure: 1 J
with protective enclosure: 7 J

Coding level according to EN ISO 14119: low

Degree of protection: IP67 to EN 60529

Connection: Boflex cable

Cable section: 4 x 0.25 mm²
EX-BNS 33-12Z(G)-2187: 6 x 0.25 mm²

Operating principle: magnetic

Actuating magnet: EX-BPS-33-3GD, coded

Assured switching distance s_{so} : 4 mm

Assured switch-off distance s_{sr} : 14 mm

Switching condition indication: LED only with ordering suffix G

Required short-circuit current: 100 A

Switching voltage max.: without LED: 100 VAC / DC
with LED: 24 VDC

Switching current max.: without LED: 400 mA
EX-BNS 33-...-2187: without LED: 250 mA
with LED: 10 mA

Switching capacity max.: without LED: 10 W
EX-BNS 33-...-2187: without LED: 3 W
with LED: 240 mW

Ambient temperature: -25 °C ... +70 °C

Storage and transport temperature: -25 °C ... +70 °C

Repeat accuracy R: ≤ 0.1 x s_{so}

Max. switching frequency: approx. 5 Hz

Resistance to shock: 30 g / 11 ms

Resistance to vibration: 10 ... 55 Hz, amplitude 1 mm

2.6 Safety classification

Standards: EN ISO 13849-1

B_{10D} (NC/NO contact): 25,000,000
at max. 20 % contact load

Mission time: 20 years

$$MTTF_D = \frac{B_{10D}}{0,1 \times n_{op}} \quad n_{op} = \frac{d_{op} \times h_{op} \times 3600 \text{ s/h}}{t_{cycle}}$$

(Determined values can vary depending on the application-specific parameters h_{op} , d_{op} and t_{cycle} as well as the load.)

An individual switch can be used in a category 3 or 4 architecture up to PL e.

If multiple safety components are wired in series, the Performance Level to EN ISO 13849-1 will be reduced due to the restricted error detection under certain circumstances.

3. Mounting

3.1 General mounting instructions



Mounting is only permitted in a de-energised state.



During fitting, the requirements of EN ISO 14119 must be observed.



For mechanical protection, the safety sensor must be fitted with the protective enclosure (in the scope of delivery).

- Do not use the protective enclosure and the actuator as a mechanical stop
- Any mounting position, provided that the active surfaces are opposite
- The safety sensor must be covered on the top side by the protective enclosure and on the bottom side by the screw-on surface (see dimensional drawing of the protective enclosure).
- When bolting the protective enclosure, align it so that there is a 3 mm clearance between the safety sensor and enclosure at the top and bottom (see dimensional drawing of the protective enclosure). The safety sensor must not rest against the protective housing.
- The minimum screw-on torque of the protective enclosure is 1.2 Nm.
- Fasten the actuator to the guard system in such a way that it cannot be detached (fixing bolts available as accessories).
- The minimum screw-on torque of the actuator is 1.2 Nm.
- Ensure the safety sensor is mounted on a flat surfaces to avoid tensile stresses that could damage the sensor or lead to varying switching distances
- Do not install the safety sensor and the actuator in strong magnetic fields
- If possible, do not mount the sensor and the actuator on ferromagnetic material. The use of non-magnetic fixing screws is recommended also.
- Do not subject the safety sensor and actuator to extreme vibrations and shocks.
- Keep away from metal chips
- The mounting distance between two sensors should always be at least 50 mm.



The actuator must be permanently fitted to the safety guards and protected against displacement by suitable measures (tamperproof screws, gluing, drilling of the screw heads).

3.2 Dimensions

All measurements in mm.

Safety sensor

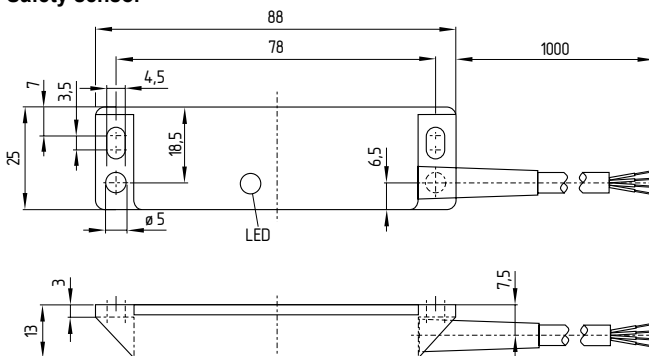

Actuator

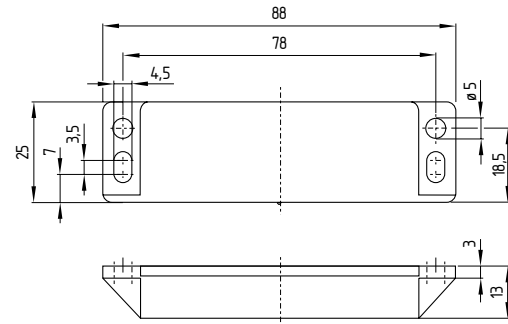

Protective enclosure

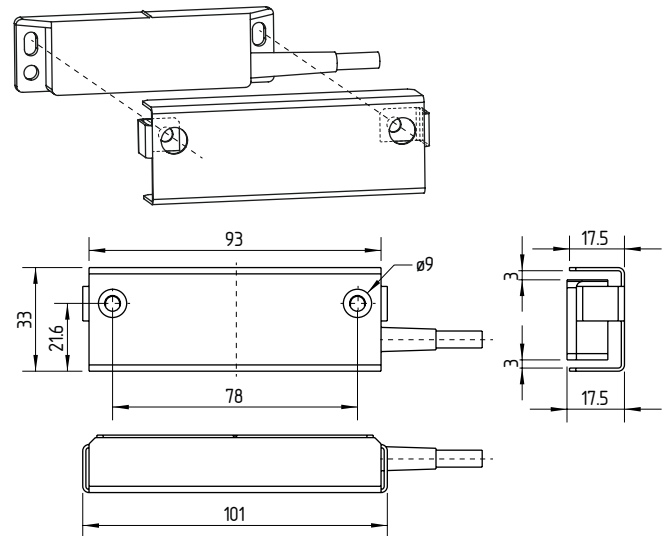

3.3 Accessories

Set of disposal screws (to be ordered separately)

- 2 x M4x12 excl. washers, ordering code 103050555

3.4 Axial misalignment

A horizontal and vertical misalignment of the safety sensor and the actuator is tolerated. The possible misalignment depends on the distance of the active surfaces of the sensor and the actuator. The sensor remains active within the tolerance range.

The specified switching distances refer to oppositely mounted safety sensors and actuators. Different arrangements are possible, however this may lead to different switching distances.

3.5 Adjustment

If the central marking of the actuator is within the represented base position area, a release signal is given at the connected safety-monitoring module.

Switching distances for horizontal and vertical offset of the actuator to the sensor.

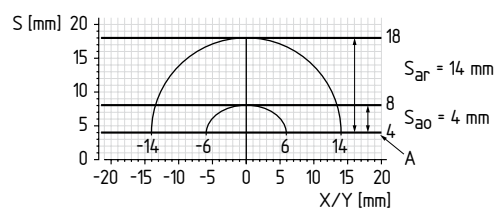

Key

A = Front protective cover surface

The LED can only be used as rough setting tool. The correct functionality of both safety channels must be checked by means of the connected safety-monitoring module.

4. Electrical connection

4.1 General information for electrical connection



The electrical connection may only be carried out by authorised personnel in a de-energised condition.

The safety sensors must be wired in accordance with the specified wire or pin colours.

4.2 Contact Options

The contact position shows the actuated sensor function when the safety guard is closed.

Safety contacts: S21-S22
S13-S14

EX-BNS 33-11Z-3G/D

BK 13 — 14 BU
WH 21 — 22 BN

Safety contacts: 02Z: S11-S12 und S21-S22
12Z: S21-S22 und S31-S32

Signalling contacts: 12Z: S13-S14

EX-BNS 33-12Z(G)-2187-3G/D

GY 13 — 14 PK
GN 21 — 22 YE
WH 31 — 32 BN

EX-BNS 33-02Z(G)-2187-3G/D

BK 11 — 12 BU
WH 21 — 22 BN

4.3 Connection

For safety-monitoring modules with NC and NO input, the wires of the EX-BNS 33-11Z(G)-3G/D safety sensor must be wired as follows:

NC contacts: WH (21) und BN (22) at the "NC input" of the safety-monitoring module

NO contacts: GY (13) und PK (14) at the "NO input" of the safety-monitoring module

For safety-monitoring modules with two NC inputs, the wires of the EX-BNS 33-12Z(G)-2187-3G/D safety sensor must be wired as follows:

NC contacts: WH (21) und BN (22) at the "NC input" of the safety-monitoring module

NC contacts: GN (31) und YE (32) at the "NC input" of the safety-monitoring module

NO contacts: GY (13) und PK (14) can be used for signalling purposes.



Information for the selection of suitable safety-monitoring modules can be found in the Schmersal catalogues or in the online catalogue on our website: products.schmersal.com.

Connecting multiple safety sensors without LED to one suitable safety-monitoring module is technically possible. To connect multiple safety sensors (check if authorised!), their NO contacts are wired in parallel and their NC contacts in series. The Protect-IE-11 or PROTECT-PE-11 (-AN) input expander module can be used to connect up to 4 safety sensors with NC/NO contacts.

If safety sensors with LED's are used, the light intensity of the LED's will decrease as the number of open safety guards increases. Safety sensors equipped with LED's shall not be wired in series, except for the Protect-IE input expander module. As a result of this, the luminosity of the LED's would considerably decrease and the voltage could drop below the minimum input voltage of the downstream safety-monitoring module.

In case of series-wiring at SRB max. 1 sensor with LED indication for U_N .

Inductive loads (e.g. contactors, relays, etc.) are to be suppressed by means of a suitable circuit. If the EX-BNS 33 with LED is used in conjunction with an inappropriate safety-monitoring module, the energy restriction for LED versions (24 V/10 mA) must be ensured by the user.

5. Set-up and maintenance

5.1 Functional testing

The safety function of the safety components must be tested. The following conditions must be previously checked and met:

1. The installation is executed according to the instructions
2. The connection is executed correctly
3. The safety component is not damaged
4. The system is free of dirt and soiling (in particular metal chips)
5. Check cable entry and connections in a de-energised condition

5.2 Maintenance

In the case of correct installation and adequate use, the safety sensor features maintenance-free functionality. A regular visual inspection and functional test, including the following steps, is recommended:

- Check safety sensor, protective enclosure and actuator for tight fit.
- Check the supply line for damage
- Remove possible metal chips
- The device must be cleaned with a damp cloth.
- Check cable entry and connections in de-energised condition



Avoid electrostatic charging. Clean with damp cloth. Do not open the device under tension.



Adequate measures must be taken to ensure protection against tampering either to prevent tampering of the safety guard, for instance by means of replacement actuators.

Damaged or defective components must be replaced.

6. Disassembly and disposal

6.1 Disassembly

The safety switchgear must be disassembled in a de-energised condition only.

6.2 Disposal

The safety switchgear must be disposed of in an appropriate manner in accordance with the national prescriptions and legislations.

7. EU Declaration of conformity

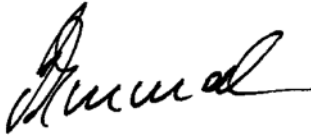
EU Declaration of conformity		
Original	K.A. Schmersal GmbH & Co. KG Möddinghofe 30 42279 Wuppertal Germany Internet: www.schmersal.com	
We hereby certify that the hereafter described components both in their basic design and construction conform to the applicable European Directives.		
Name of the component:	EX-BNS 33	EX-BPS 33
Type:	see ordering code	
Marking	EX-BNS 33 Ⓢ II 3G Ex nC IIC T6 Gc X Ⓢ II 3D Ex tc IIIC T80°C Dc X	EX-BPS 33 Ex h IIC T6 Gc Ex h IIIC T80°C Dc
Description of the component:	Coded safety-sensor with magnetic operating principle in combination with the SRB(-E) / PROTECT-SELECT / PSC1 safety-monitoring modules from Schmersal or an equivalent safety-oriented control system fulfilling the requirements of the EN 60947-5-3.	
Relevant Directives:	Machinery Directive Explosion Protection Directive (ATEX) RoHS-Directive	2006/42/EC 2014/34/EU 2011/65/EU
Applied standards:	EN 60947-5-3:2013 EN IEC 60079-0:2018 EN IEC 60079-15:2019 EN 60079-31:2014 EN ISO 80079-36:2016 EN ISO 80079-37:2016	
Notified body, which approved the full quality assurance system, referred to in Appendix IV, 2014/34/EU:	TÜV Rheinland Industrie Service GmbH Am Grauen Stein 51105 Köln ID n°: 0035	
Person authorised for the compilation of the technical documentation:	Oliver Wacker Möddinghofe 30 42279 Wuppertal	
Conformity with the explosion protection directive 2014/34/EU (ATEX) is declared by the manufacturer without involving a test center.		
Place and date of issue:	Wuppertal, March 13, 2023	
EX-BNS33-1EN		
	Authorised signature Philip Schmersal Managing Director	



The currently valid declaration of conformity can be downloaded from the internet at products.schmersal.com.



K.A. Schmersal GmbH & Co. KG
Möddinghofe 30, 42279 Wuppertal
Germany
Phone: +49 202 6474-0
Telefax: +49 202 6474-100
E-Mail: info@schmersal.com
Internet: www.schmersal.com