



EN Operating instructions.pages 1 to 4
Original

Content

1 About this document

1.1 Function 1

1.2 Target group: authorised qualified personnel. 1

1.3 Explanation of the symbols used 1

1.4 Appropriate use 1

1.5 General safety instructions 1

1.6 Warning about misuse 1

1.7 Exclusion of liability 2

2 Product description

2.1 Ordering code 2

2.2 Technical data 2

3 Assembly

3.1 General mounting instructions 2

3.2 Dimensions 3

4 Electrical connection

4.1 General information for electrical connection. 3

4.2 Wiring example 3

4.3 Connector accessories 3

5 Installation, configuration and operation

6 Diagnostic

7 Set-up and maintenance

7.1 Functional testing. 4

7.2 Maintenance 4

8 Disassembly and disposal

8.1 Disassembly. 4

8.2 Disposal 4

9 Declaration of conformity

1. About this document

1.1 Function

These operating instructions provide the necessary information for commissioning and operating the camera. The operating instructions must be available in a legible condition and a complete version in the vicinity of the device.

1.2 Target group: authorised qualified personnel

All operations described in this operating instructions manual must be carried out by trained specialist personnel, authorised by the plant operator only.

Please make sure that you have read and understood these operating instructions and that you know all applicable legislations regarding occupational safety and accident prevention prior to installation and putting the component into operation.

The machine builder must carefully select the harmonised standards to be complied with as well as other technical specifications for the selection, mounting and integration of the components.

1.3 Explanation of the symbols used



Information, hint, note:

This symbol indicates useful additional information.



Caution: Failure to comply with this warning notice could lead to failures or malfunctions.

Warning: Failure to comply with this warning notice could lead to physical injury and/or damage to the machine.

Attention: *Le non-respect de cette recommandation peut entraîner des pannes ou des défauts de fonctionnement.*

Avertissement: *Le non-respect de cette consigne peut entraîner des blessures physiques et des dommages à la machine.*

1.4 Appropriate use

The Schmersal range of products is not intended for private consumers.

The product must be exclusively used in accordance with the versions listed below or for the applications authorised by the manufacturer. Detailed information regarding the range of applications can be found in the chapter "Product description".

1.5 General safety instructions

The user must observe the safety instructions in this operating instructions manual, the country specific installation standards as well as all prevailing safety regulations and accident prevention rules.



Further technical information can be found in the Schmersal catalogues or in the online catalogue on the Internet: products.schmersal.com.

The information contained in this operating instructions manual is provided without liability and is subject to technical modifications.

There are no residual risks, provided that the safety instructions as well as the instructions regarding mounting, commissioning, operation and maintenance are observed.

1.6 Warning about misuse



In case of inadequate or improper use or manipulations of the component, personal hazards or damage to machinery or plant components cannot be excluded.

En cas d'emploi non-conforme ou non-approprié ou en cas de manipulations frauduleuses, l'utilisation de l'appareil est susceptible d'entraîner des risques pour l'homme ou des dégâts matériels.

1.7 Exclusion of liability

We shall accept no liability for damages and malfunctions resulting from defective mounting or failure to comply with this operating instructions manual. The manufacturer shall accept no liability for damages resulting from the use of unauthorised spare parts or accessories.

For safety reasons, invasive work on the device as well as arbitrary repairs, conversions and modifications to the device are strictly forbidden, the manufacturer shall accept no liability for damages resulting from such invasive work, arbitrary repairs, conversions and/or modifications to the device.

2. Product description

2.1 Ordering code

This operating instructions manual applies to the following types:

AM-T100



Laser category class I according to EN IEC 60825-1

To avoid eye damage, do not look into the laser beam while the unit is in operation.

Catégorie de laser classe I selon EN IEC 60825-1

Ne regardez pas le faisceau laser lorsque l'appareil est en fonctionnement afin d'éviter toute lésion oculaire.

2.2 Technical data

Standards:	EN 61326-1, EN IEC 60825-1
Sensor technology:	iToF (indirect Time of Flight)
Resolution (Pixel):	640×480
Pixel size (µm):	10
Frame rate (fps):	60
LD wavelength (nm):	850
Field of view:	67° x 51°
Range:	0.2 ... 6 m
Recommended target reflectivity:	20%~90%
Accuracy:	< 1%
Distance Resolution (mm):	1
Exposure range:	1 µs ~ 1 ms
CPU:	Dual Cortex-A53 1.2 GHz
Interface:	10/100/1000 Mbps Ethernet, GigE Vision 2.0 Compliant
I/O:	Opto-isolated input x 2 Opto-isolated output x 2 Isolated input, common potential x 1 Isolated output, common potential x 1 DC power input x 1 DC power ground x 1
LED display:	Power (Green) x 1 Status (Green / Red / Orange) x 1 User defined (Green) x 1 User defined (Red) x 1
Power supply:	PoE: IEEE802.3bt DC: 24 V ± 10%
Power consumption:	Typical: 15 W Peak: 40 W
Connection:	A-coded 8-pole M12 I/O connector x 1 X-coded M12 Ethernet connector x 1
Weight:	500 g
Degree of protection:	IP67, when both plug connections are closed; Not evaluated by UL.
Eye safety:	Class I
Temperature:	Storage: -20 °C ... 85 °C Operation: 0 °C ... 45 °C
The device can be operated under -20°C after 30-minute warm up.	
Vibration:	IEC 60068-2-6: 5 Hz ≤ f ≤ 8.4 Hz Single amplitude: 3.5 mm, 8.4 Hz < f ≤ 150 Hz Acceleration: 1 G
Shock:	IEC 60068-2-27: Semi-sinusoid; Acceleration: 15 G; 3 axes, 6 directions; 3 times each

3. Assembly

3.1 General mounting instructions



Fitting is only authorised in a de-energised condition

- Do not install the unit near high-voltage equipment and power consumers.
- Keep the components away from metal scrap that could affect operation or damage the components.
- Do not use the unit in places where flammable or explosive gases are present.



In order to optimally dissipate the heat generated during operation and to guarantee the performance data of the camera over the entire operating temperature range, the camera must be mounted in such a way that the heat is dissipated. This is done via a suitable holder or via contact surfaces between the housing and the environment. Be sure to observe the information in the manual (see chapter 5).

Afin de dissiper au mieux la chaleur générée lors du fonctionnement et de garantir les performances de la caméra sur toute la plage de températures de fonctionnement, la caméra doit être montée de manière à dissiper la chaleur. Cela se fait via un support adapté à cet effet ou via des surfaces de contact entre le boîtier et l'environnement. Respectez impérativement les indications du manuel (voir chapitre 5).



Please note that the waterproofness is only given if both cables are laid behind the unit and the plugs are properly tightened.

Do not remove the screws on the back panel as this will compromise the waterproofness.

Veillez noter que l'étanchéité à l'eau n'est assurée que si les deux câbles sont posés derrière l'appareil et que les fiches sont correctement serrées.

Ne retirez pas les vis de la paroi arrière afin de ne pas compromettre l'étanchéité.

For mounting the camera, M5 fixing holes are provided for hexagon socket screws (e. g. M5x80). Screws and washers are not included in the scope of delivery.

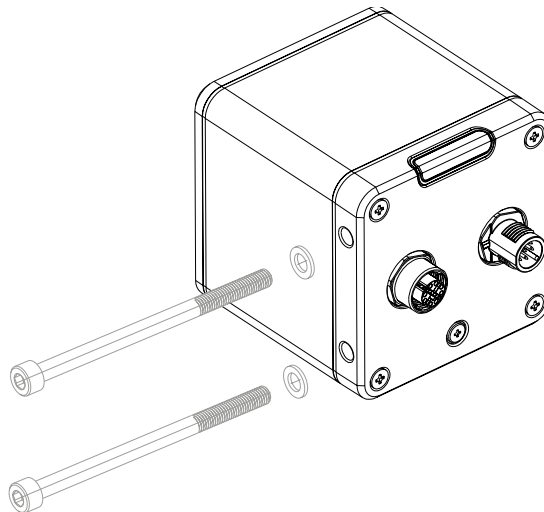

3.2 Dimensions

All measurements in mm.

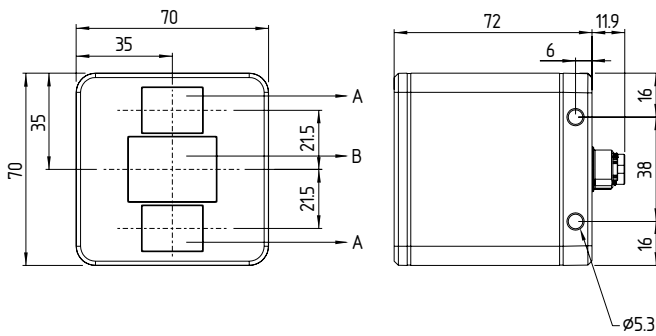

Key

- A Laser diode
- B Lens

4. Electrical connection

4.1 General information for electrical connection



The electrical connection may only be carried out by authorised personnel in a de-energised condition.

- To avoid damage due to an incorrect input voltage level, please make sure that all signal connections, such as input voltage and polarity, are correct before switching on a component.
- Make sure the system is switched off before checking the input power source or connecting the cables. To avoid electric shock, never touch the terminals or connect the cables when the system is switched on.
- The product is an enclosed-type Area Scan Camera, supplied by Class 2, SELV, LE or LPS power source, intended for use in industrial applications.

The connection is made via an 8-pole M12 connector and an RJ45 Ethernet connector.

4.2 Wiring example

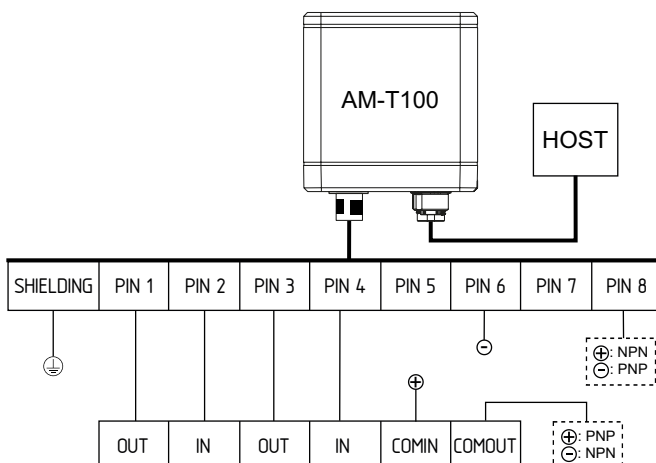

4.3 Connector accessories

ACC-AM-CON-A-K8P-M12-G-5M-S, 103048464 Connecting cable M12 8 pole, A-coded

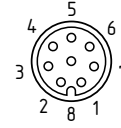

PIN	Function	Colour code of the Schmersal connector plug to DIN 47100
1	Optoisolated input 0	WH
2	Optoisolated outputs 0	BN
3	Optoisolated input 1	GN
4	Optoisolated outputs 1	YE
5	DC supply	GY
6	Isolated output, common potential	PK
7	DC power ground	BU
8	Isolated input, common potential	RD

ACC-AM-CON-VIE-SS8P-M12-RJ45-G-5M-S, 103048465 Ethernet connector M12, X-coded

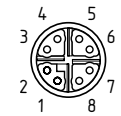

M12, 8 pole PIN	Signal	RJ45, 8P8C PIN
1	BI_DA+	1
2	BI_DA-	2
3	BI_DB+	3
4	BI_DB-	6
5	BI_DC+	7
6	BI_DC-	8
7	BI_DD+	5
8	BI_DD-	4

5. Installation, configuration and operation

Installation, configuration and operation are described in separate manuals. Please go to products.schmersal.com and enter the search term "AM-T100". Under "Documents" you will find the corresponding manuals as PDF files.



Do not operate the appliance unless you have read and understood the operating instructions.

Ne mettez l'appareil en service que si vous avez lu et compris le mode d'emploi.

6. Diagnostic

The camera signals the operating status via the assigned LEDs on the back of the unit.

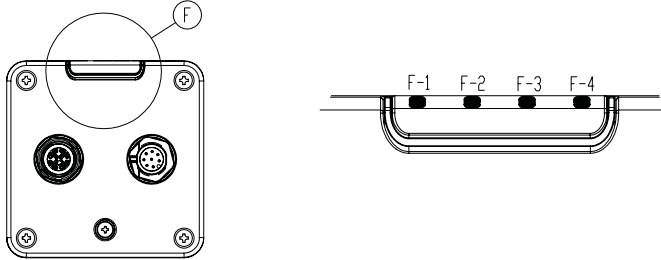

Key

F	LED display
F-1	Power (green)
F-2	No function
F-3	No function
F-4	Status (green / red / orange)

Power display

	OFF	Continuous light
Green	Power supply error	Power supply normal

Status display

	flashing	Continuous light
Red	Error, camera not working, please check configuration	Error, camera not working. If restarting with factory settings is not possible, please contact Service.
Orange	Initialisation	Idle (waiting for connection)
Green	Capture	Ready (connected)

7. Set-up and maintenance

7.1 Functional testing

The following must be ensured before commissioning:

1. Firm fit of the camera
2. Fitting and integrity of the cable connections
3. Remove particles of dust and soiling
 - Use only compressed air to remove dust from the camera sensor and lens. To avoid getting moisture on the components, never blow air on the components with your mouth.
 - Please clean the system with a dry cloth. Do not use cleaning solutions containing acids or alkalis.
 - Cleaning with wet cloths could damage the glass coating and lead to additional contamination.

7.2 Maintenance

In the case of correct installation and intended use, the switchgear is maintenance-free.

A regular visual inspection and functional test, including the following steps, is recommended:

1. Check camera housing for damage
2. Check camera for tight fit
3. Fitting and integrity of the cable connections
4. Remove particles of dust and soiling
 - Use only compressed air to remove dust from the camera sensor and lens. To avoid getting moisture on the components, never blow air on the components with your mouth.
 - Please clean the system with a dry cloth. Do not use cleaning solutions containing acids or alkalis.

Damaged or defective devices must be replaced.

8. Disassembly and disposal

8.1 Disassembly

The camera should be disassembled when de-energised only.

8.2 Disposal

The camera must be disposed of in an appropriate manner in accordance with the national prescriptions and legislations.



9. Declaration of conformity

We declare under our sole responsibility that the products mentioned comply with all relevant provisions of the directives and regulations listed below and conform to the following standards.

Relevant Directives:



2014/30/EU
2011/65/EU



SI 2016/1091
SI 2012/3032

Applied standards:

EN 61326-1:2013
EN IEC 60825-1:2014



The currently valid declaration of conformity can be downloaded from the internet at products.schmersal.com.

K.A. Schmersal GmbH & Co. KG

Mödinghofe 30, 42279 Wuppertal
Germany

Phone: +49 202 6474-0

Fax: +49 202 6474-100

E-Mail: info@schmersal.com

Internet: www.schmersal.com